

# ➤ Instructions

**Thule Tepui Ayer 2**

**Thule Tepui Kukenam 3**

**Thule Tepui Ruggedized Kukenam 3**

901200, 901201, 901300, 901301, 901302, 901350, 901351



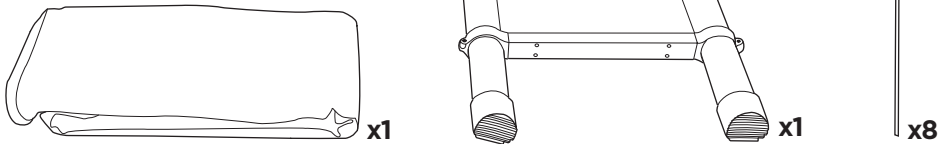
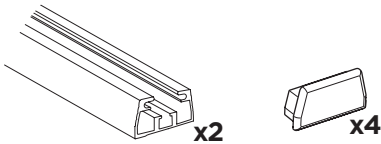
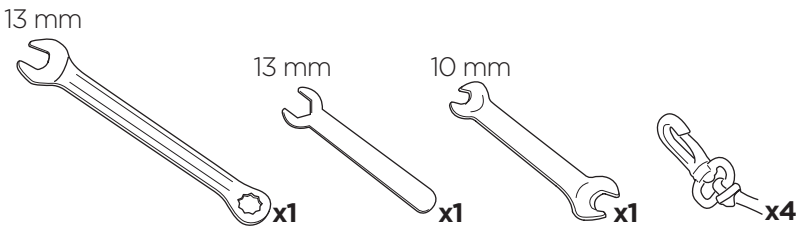
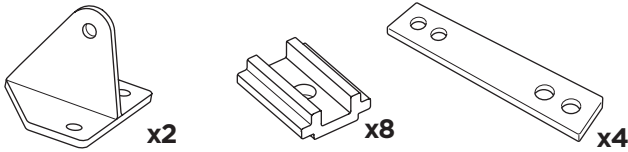
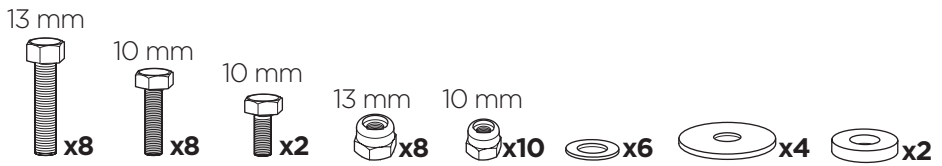
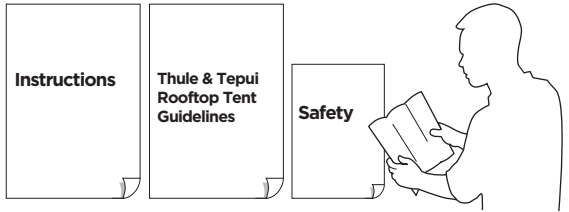

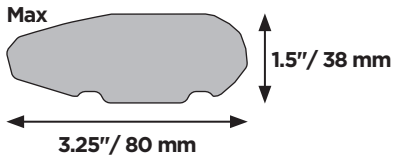

**Adapter** Thule Xsporter & Thule TracRac bar Xadapt 14

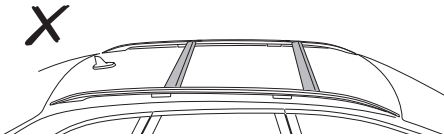
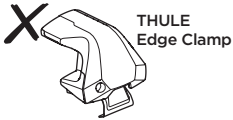
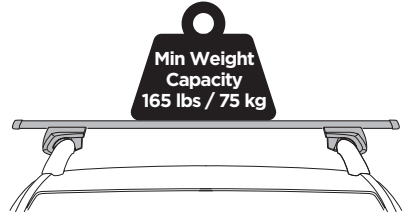
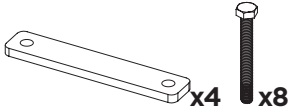

**DO NOT** use Tepui tents on factory installed crossbars.

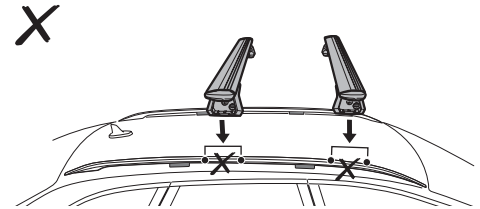
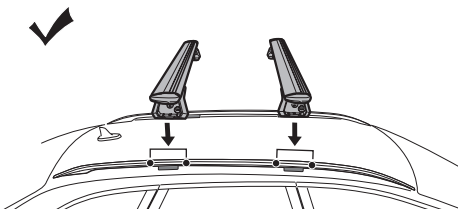
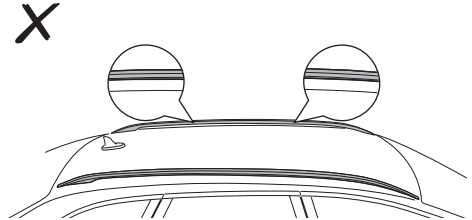
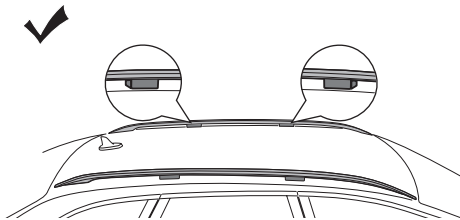
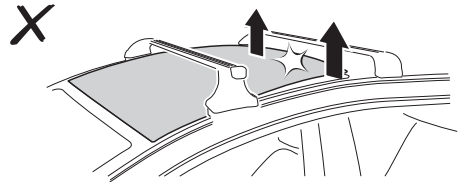

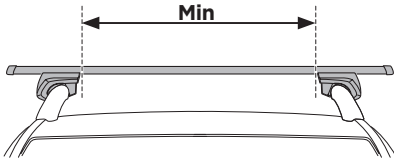

**Min 25.2"/64 cm**

**Min 33.5"/85 cm**

**THULE SquareBar Evo Max 50"/127 cm**



**Max 130 km/h  
80 Mph**

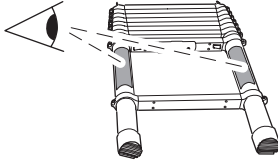

**136 kg  
300 lbs**

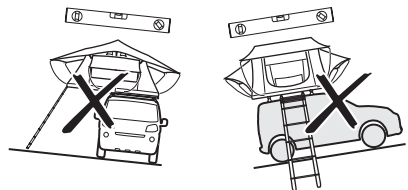
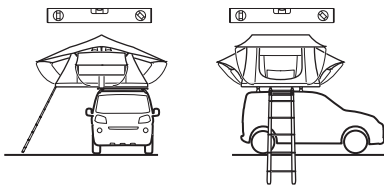
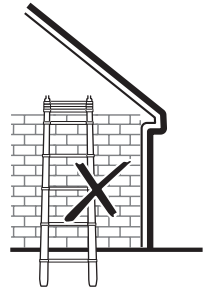
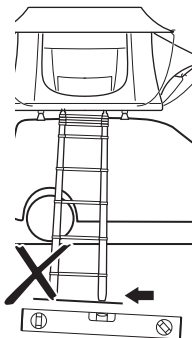
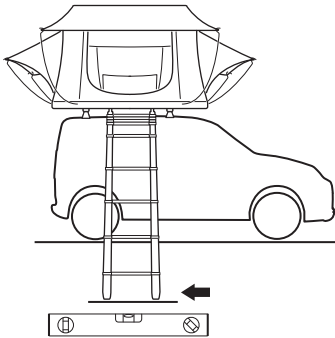
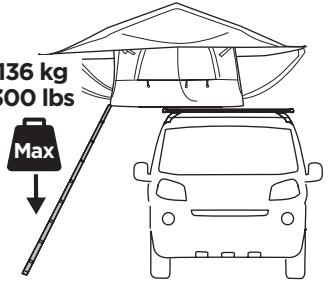

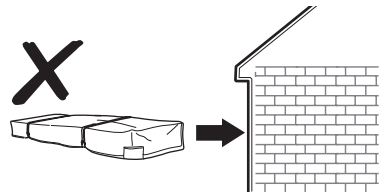
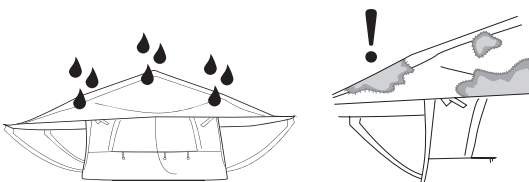
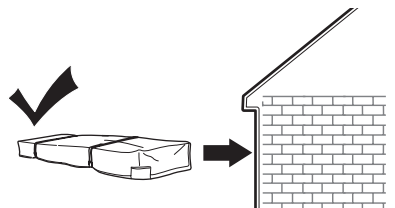
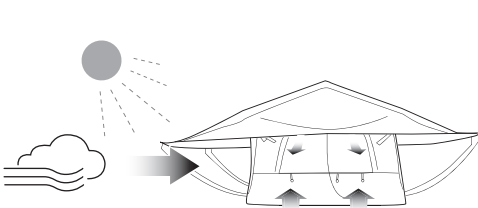
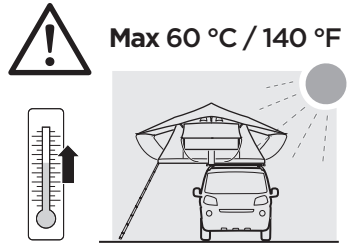
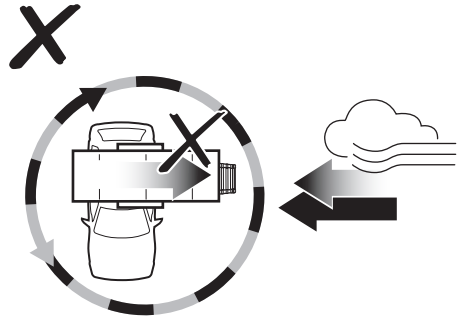
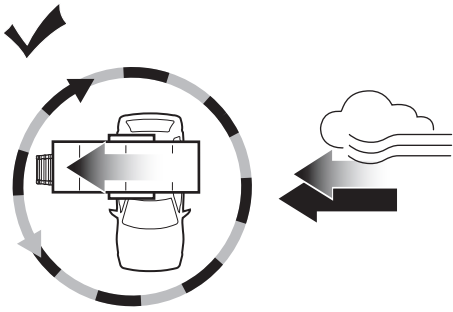

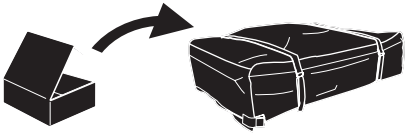

1

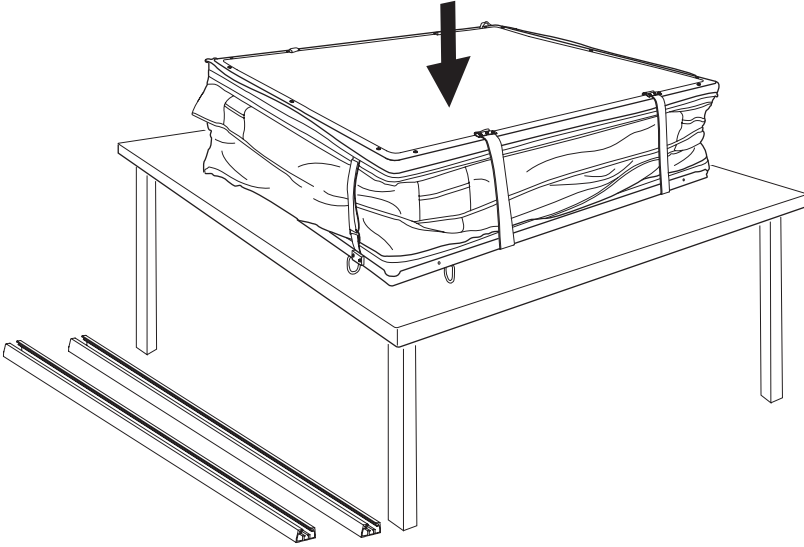

2

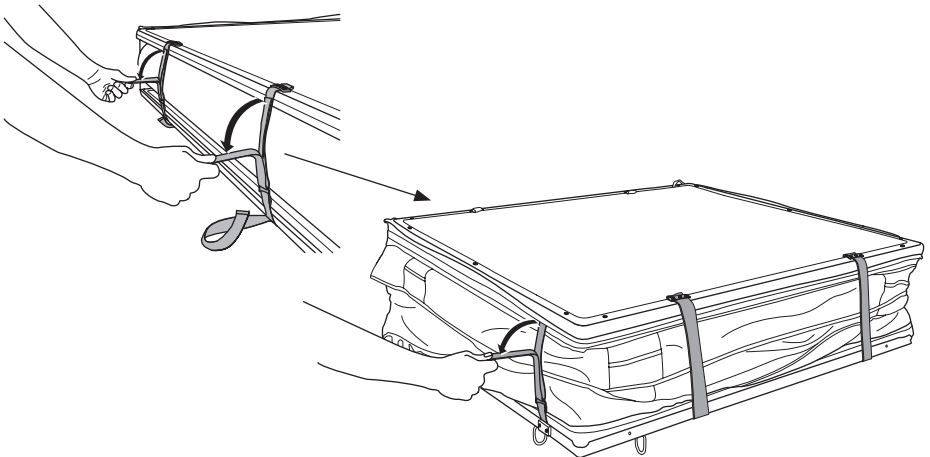

3

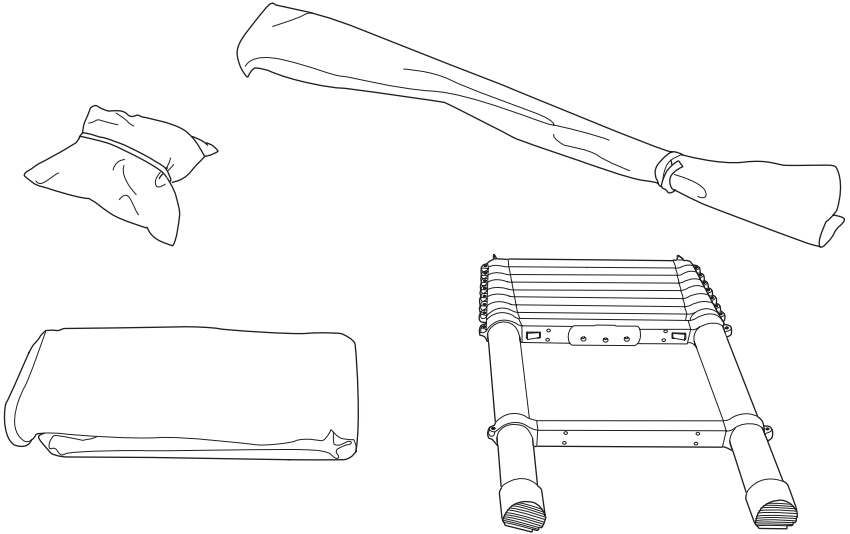
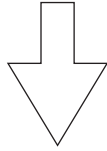
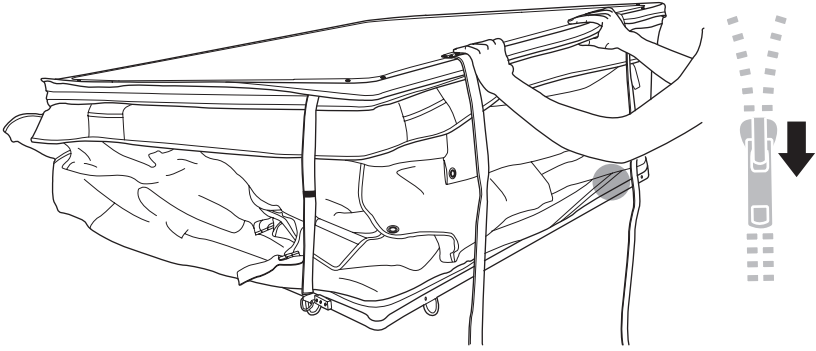

**i**

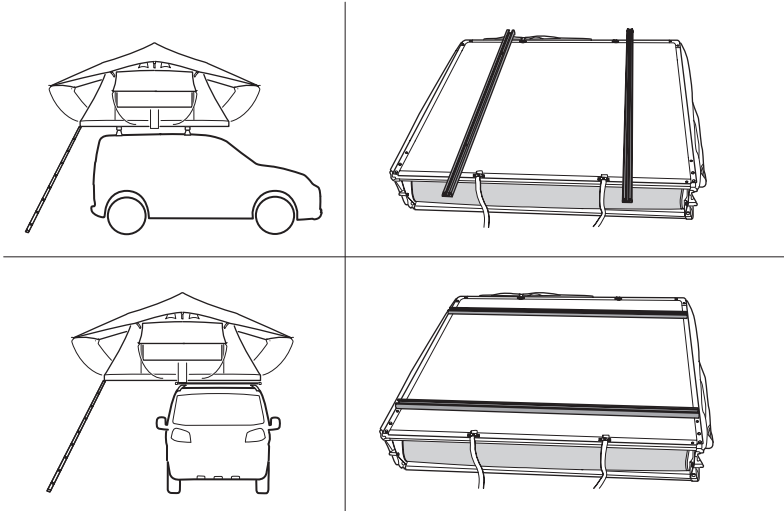

**4**

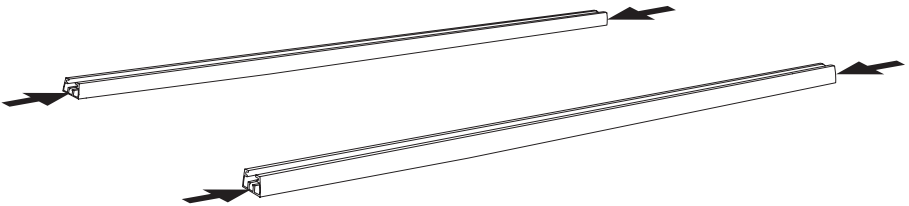
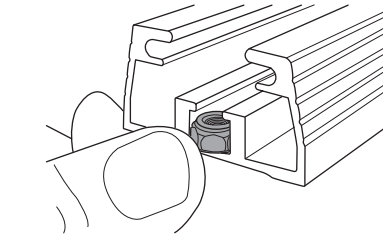
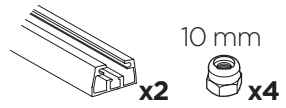



5

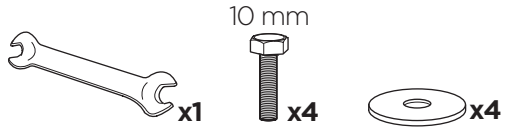

A

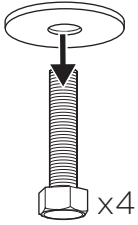

B

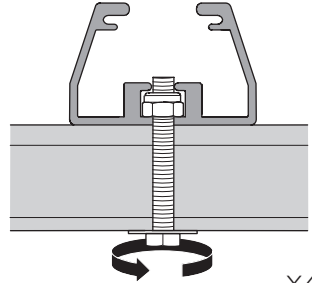
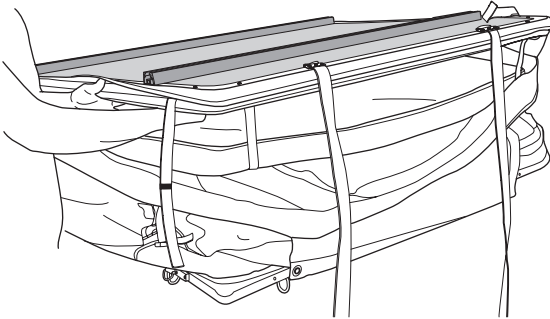

i

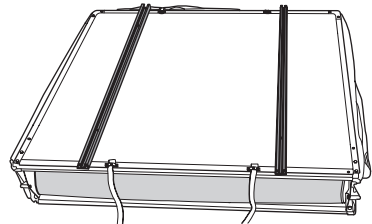
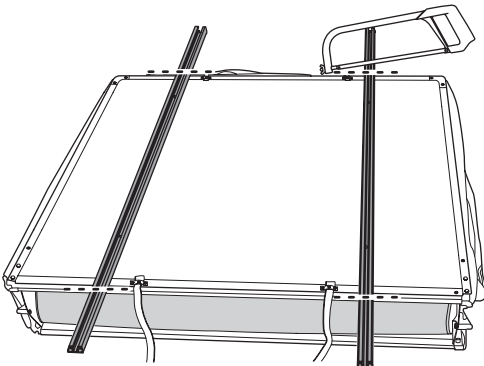
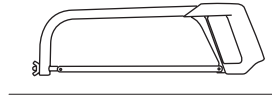
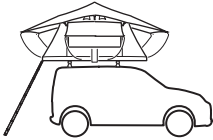

6

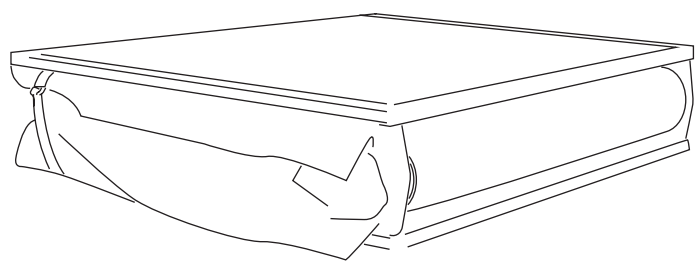
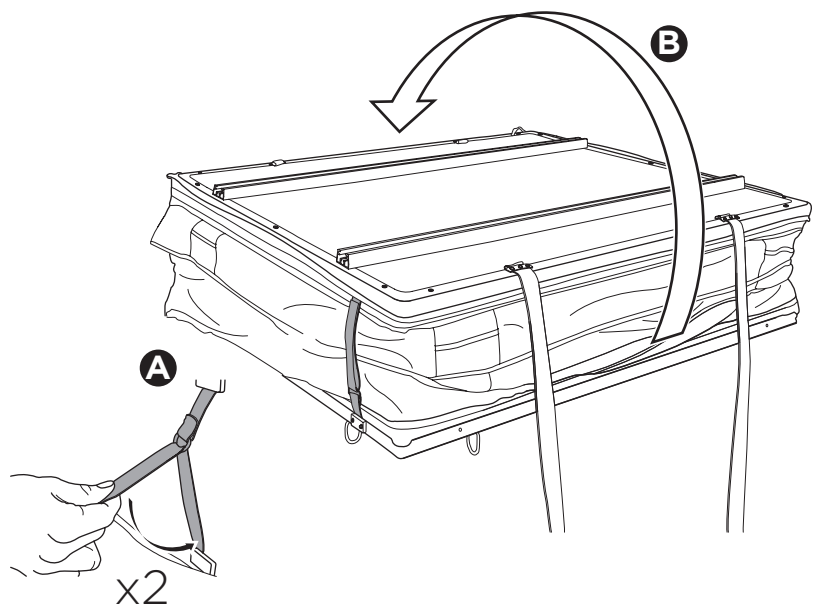

7

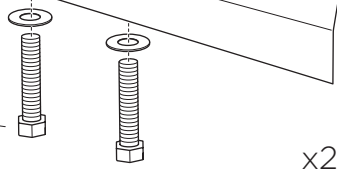
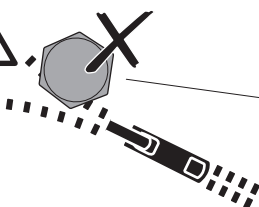
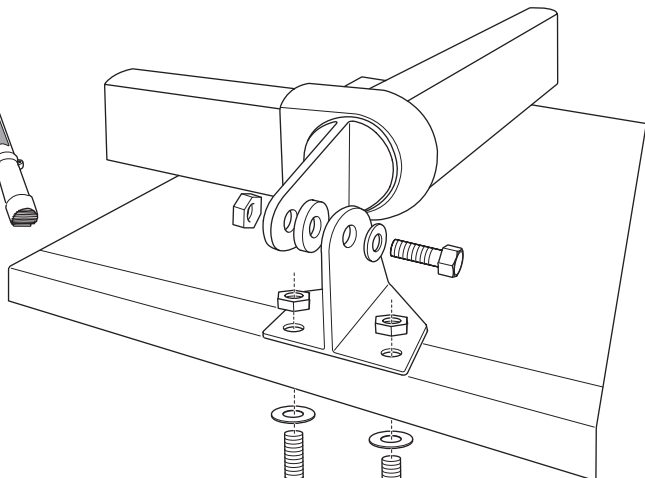
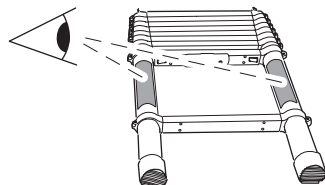
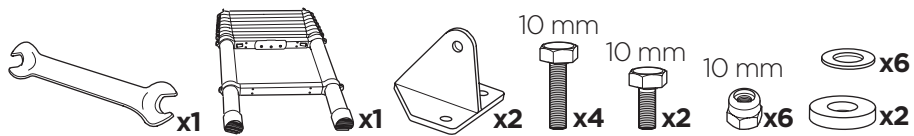

8

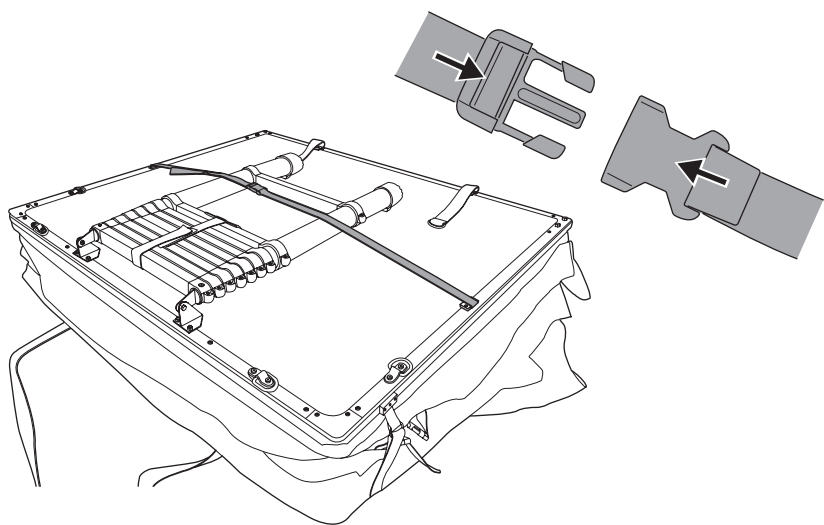

9

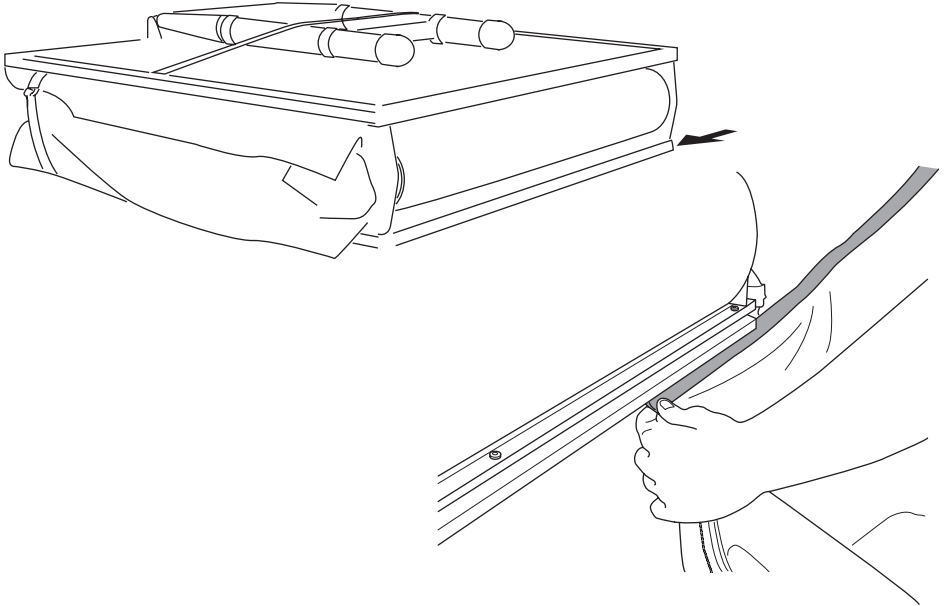
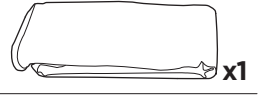

10

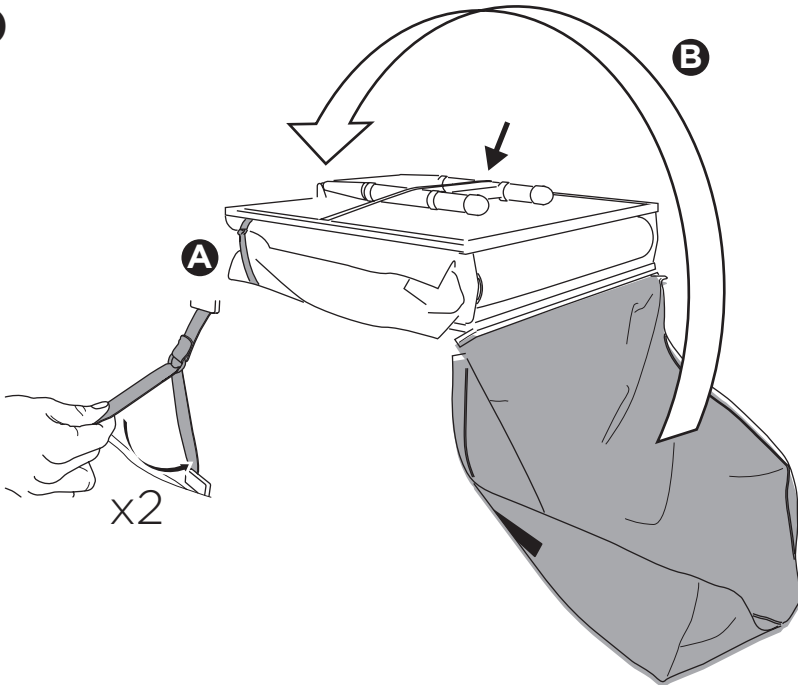

11

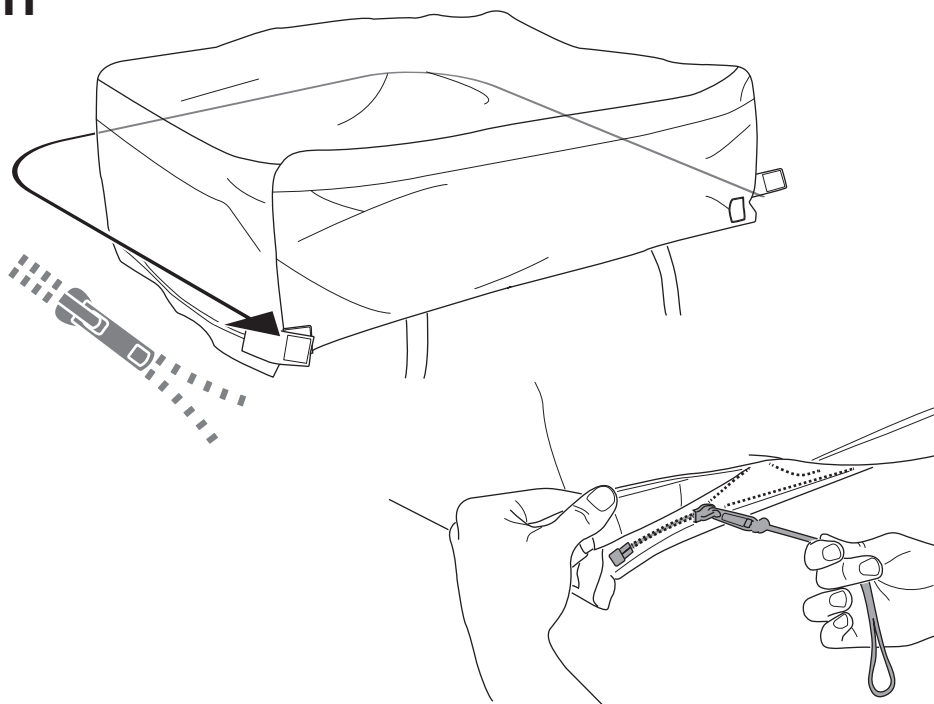

12

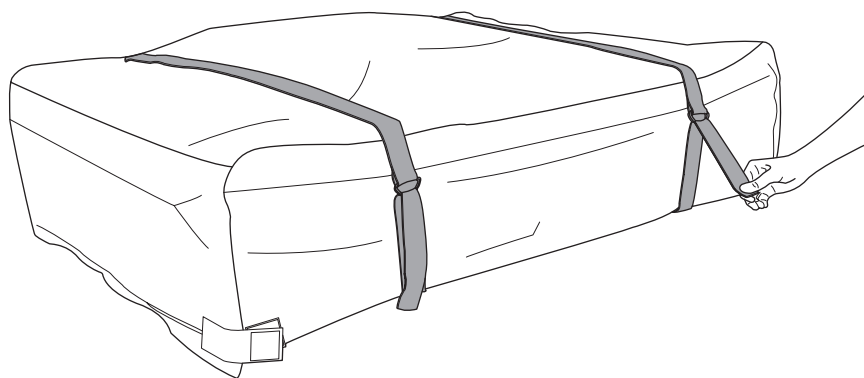

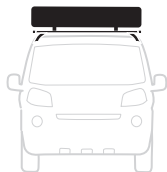

1

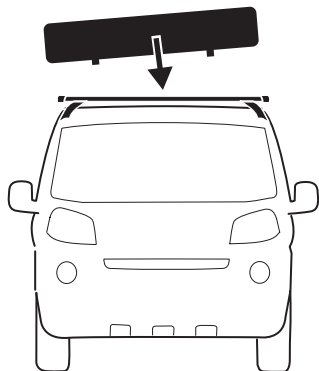

i

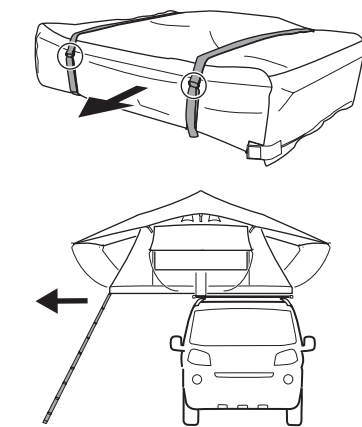

2

13 mm



x8

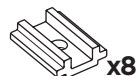

x8

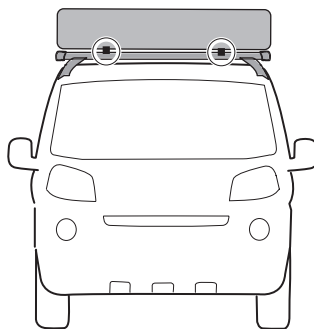
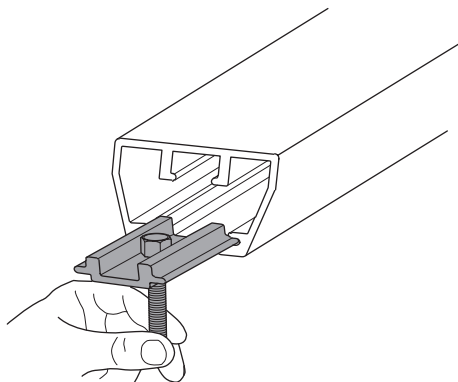

x8

3

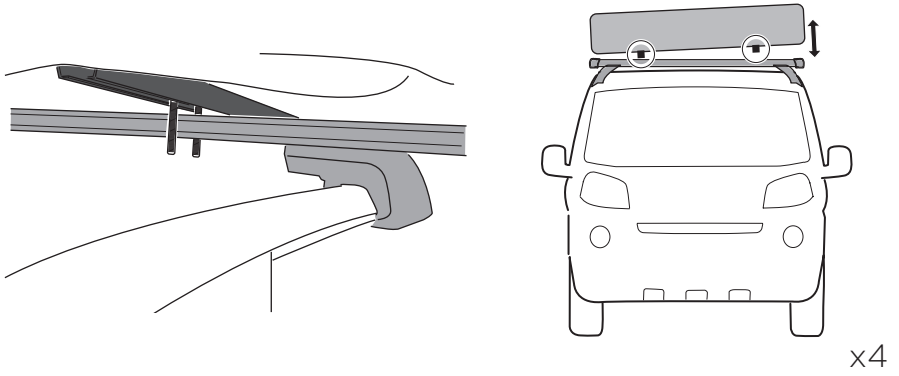

4

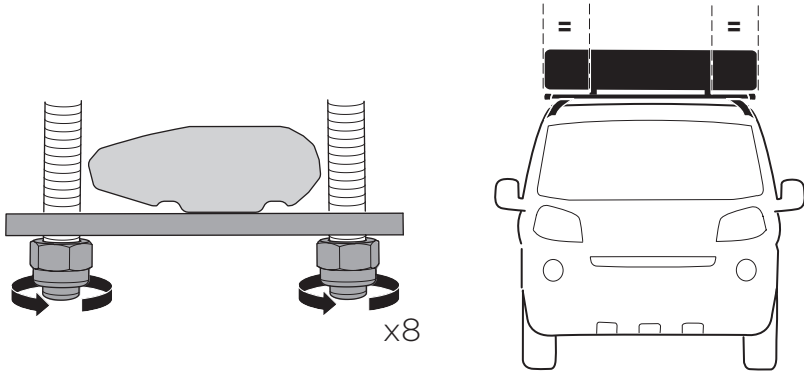

5

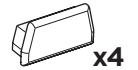
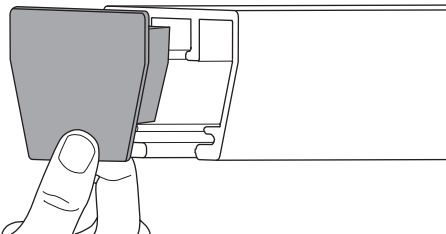

x4

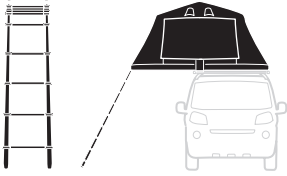

1

A

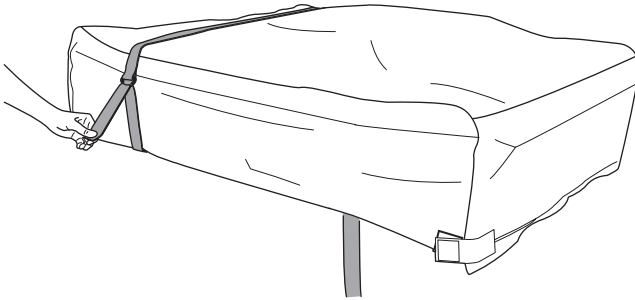

B

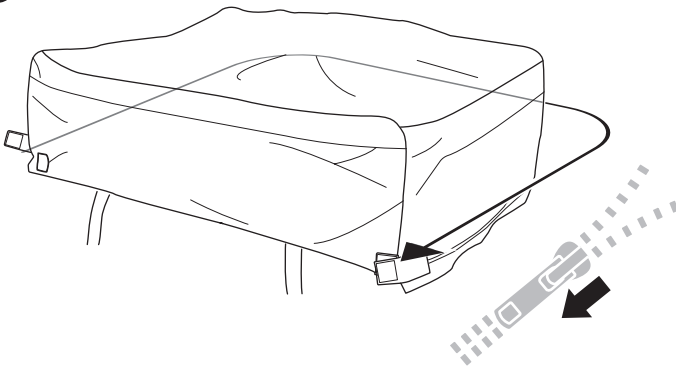



2

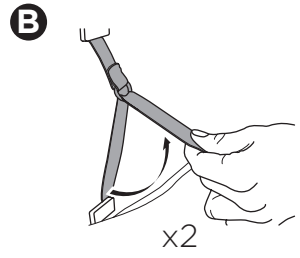
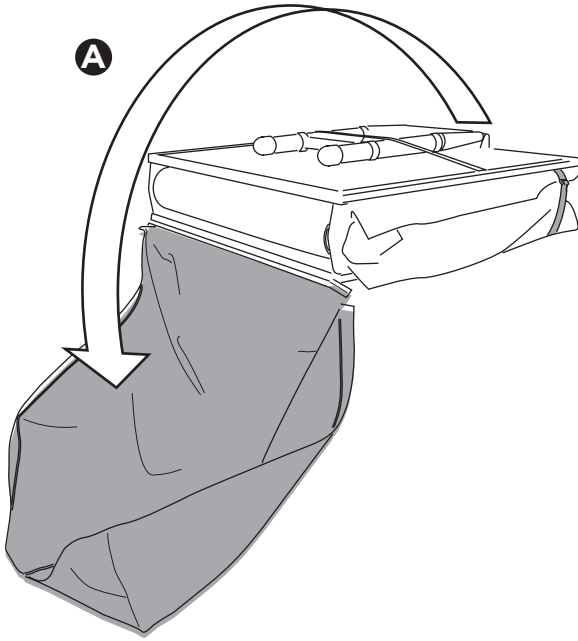

3

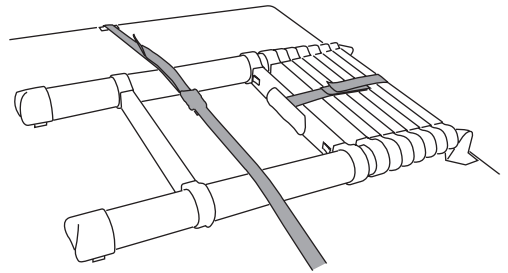
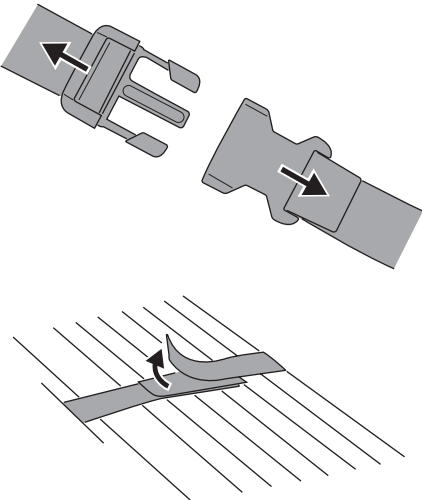

4

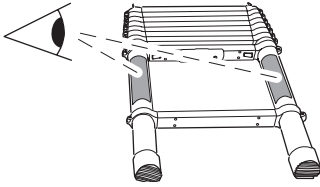

*click click click click click*

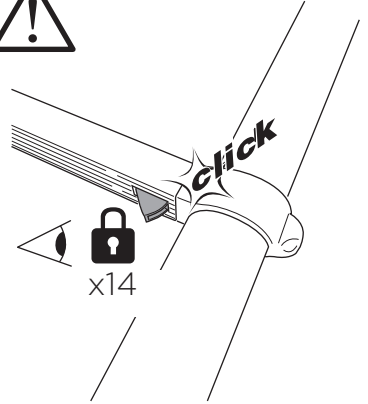
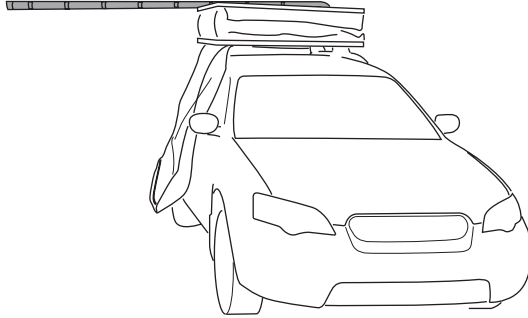

x14

5

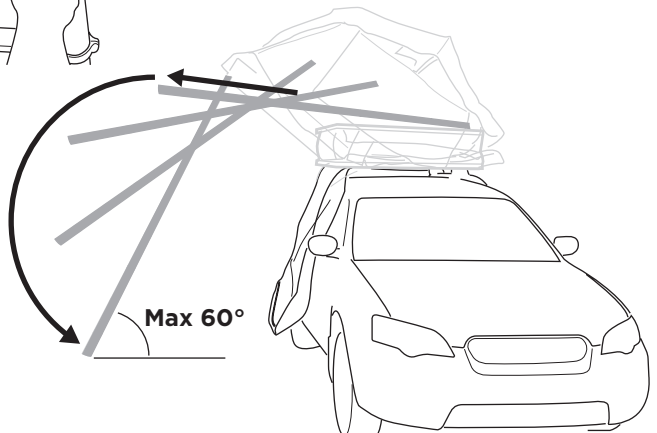
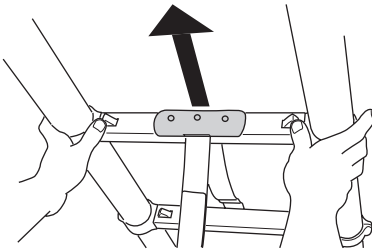

Max 60°

# 6

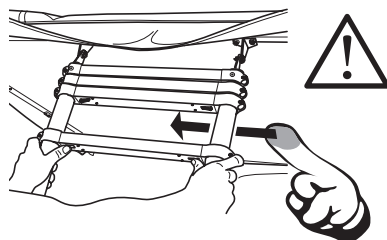
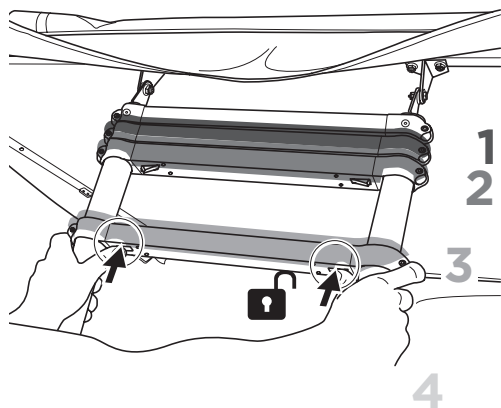
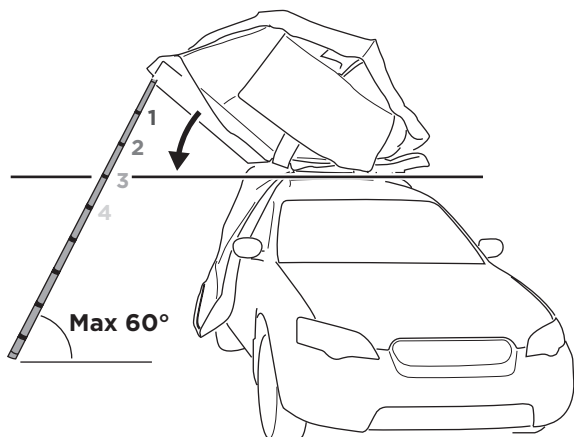

7

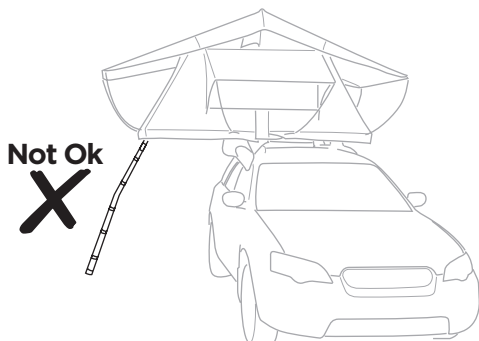
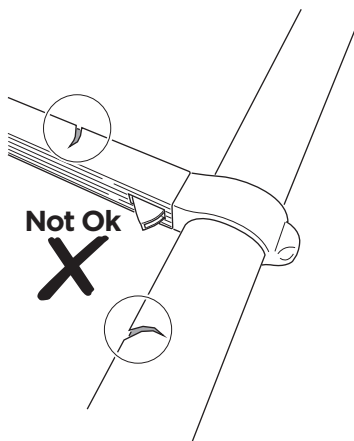
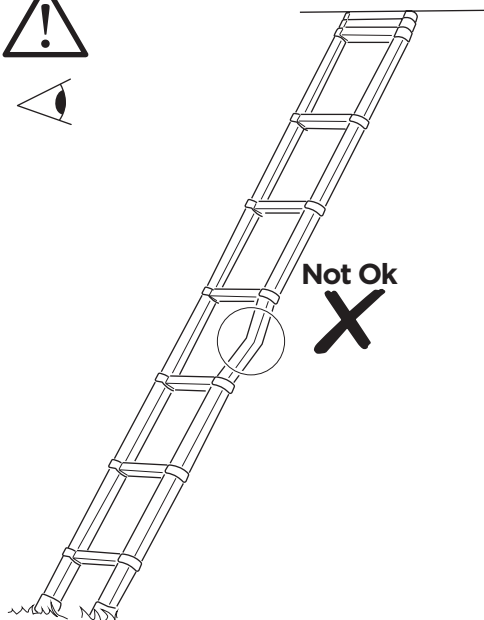
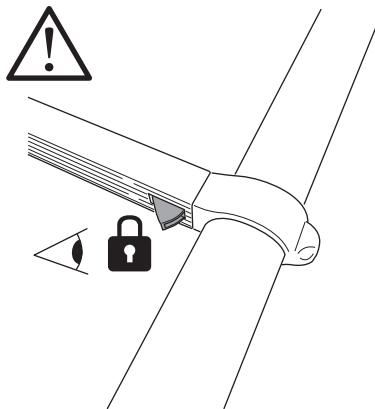
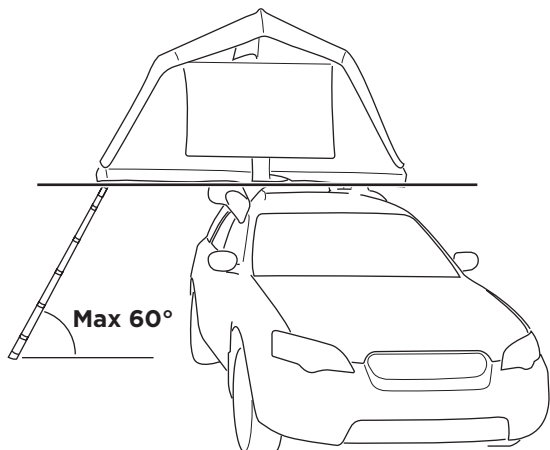

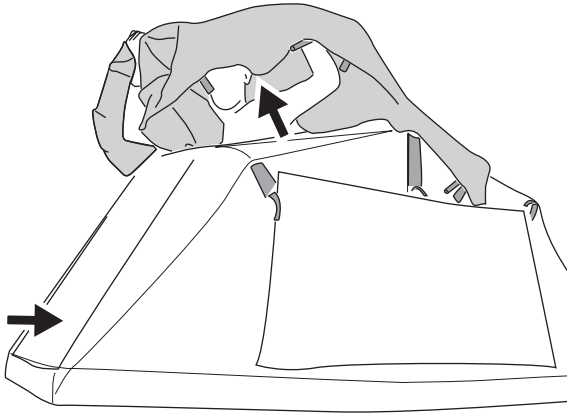
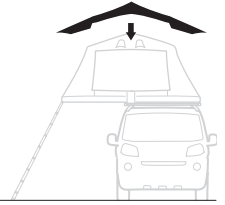

**A**

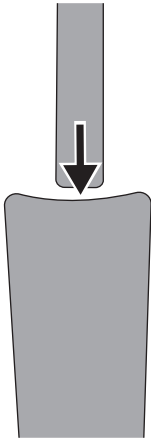

x6

**B**

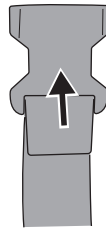
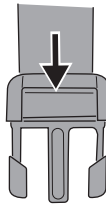

x6

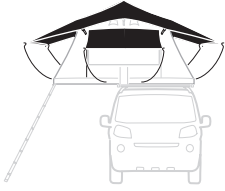

1

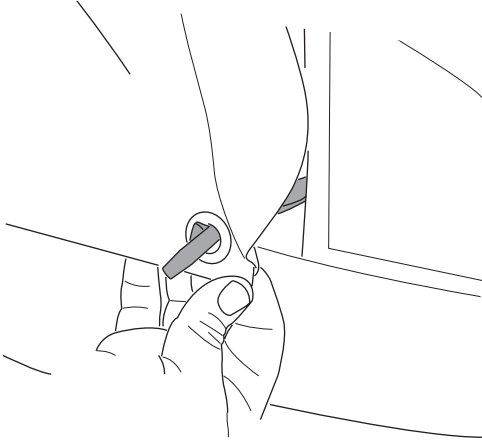

2

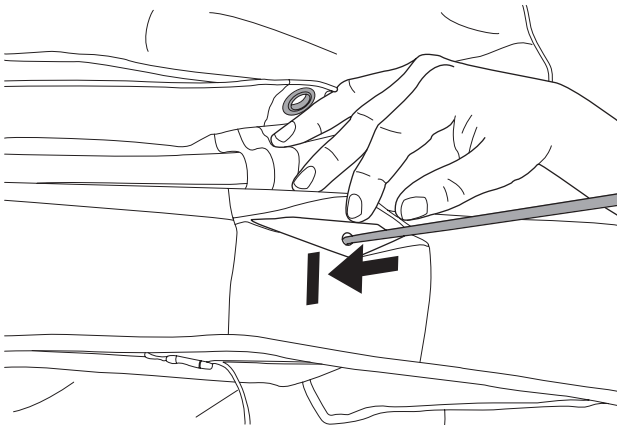

x8

3

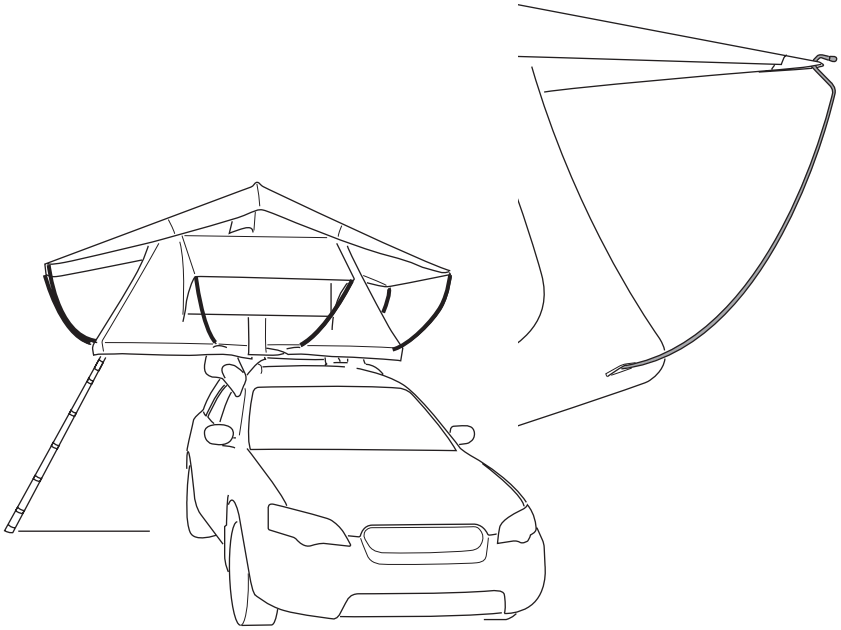

4

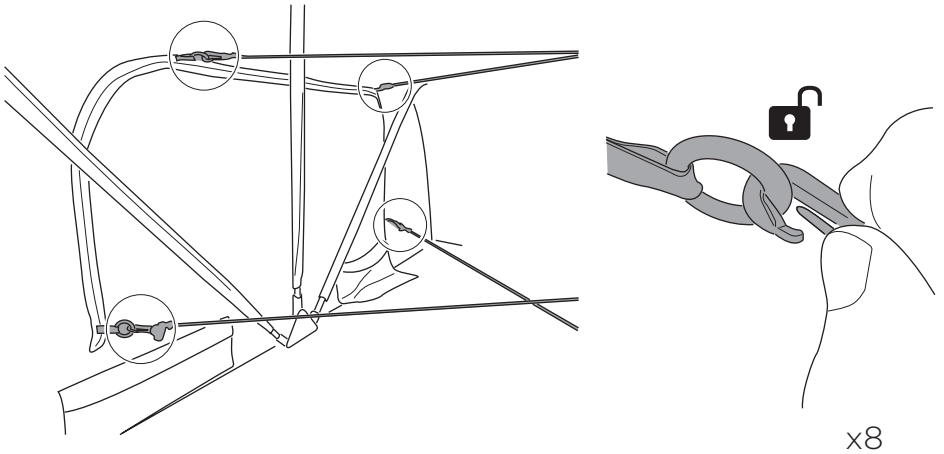

x8

**i**

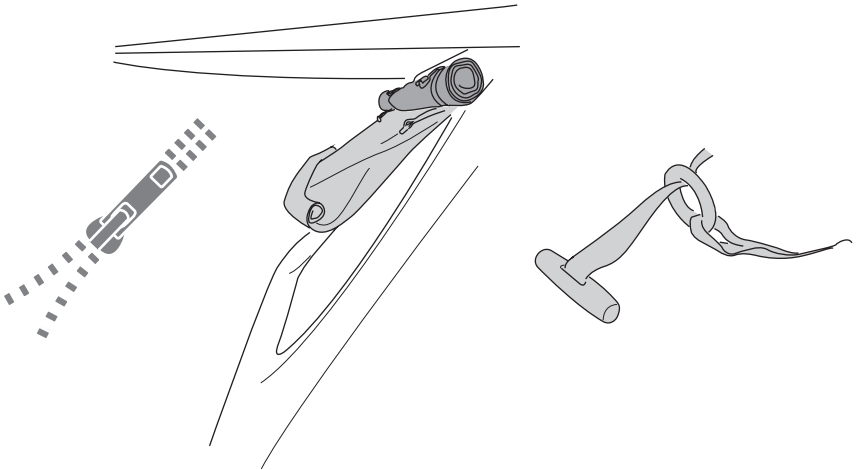
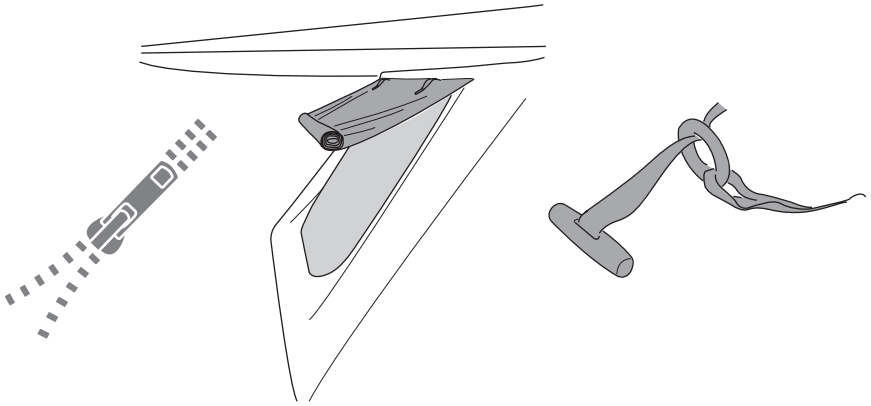

**i**

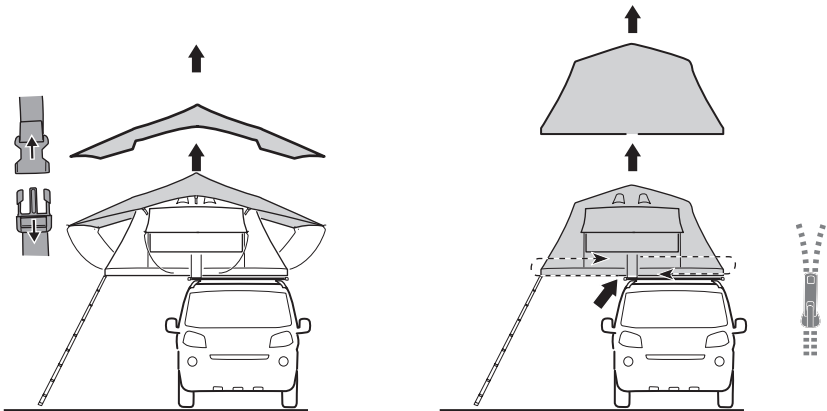





1

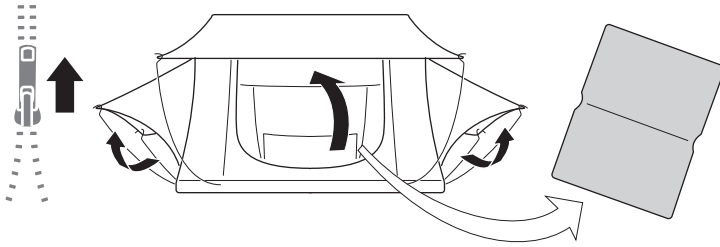

2

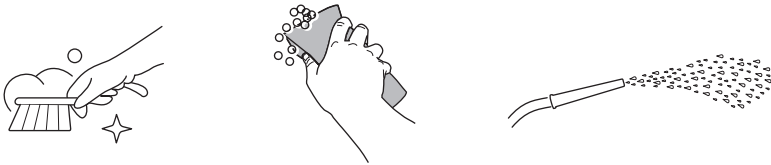

3

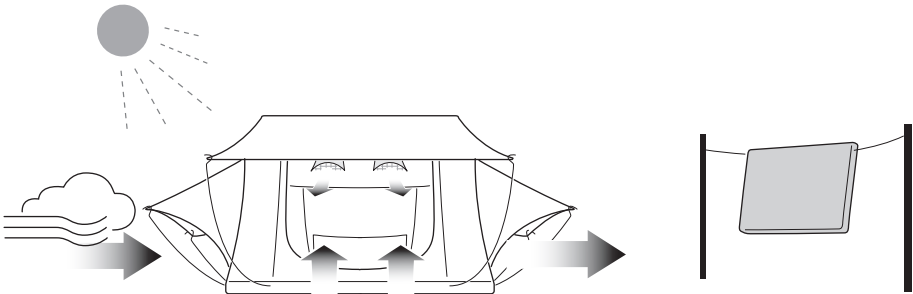

4

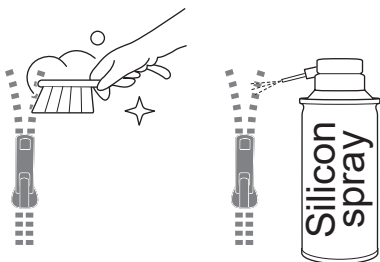



1

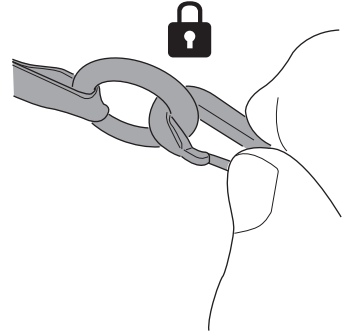
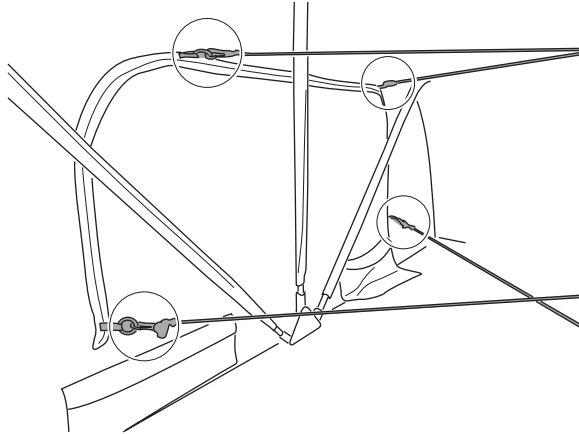

x8

2

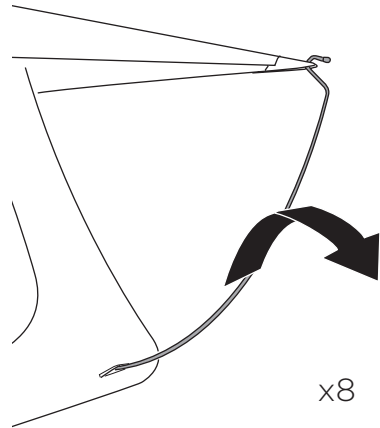
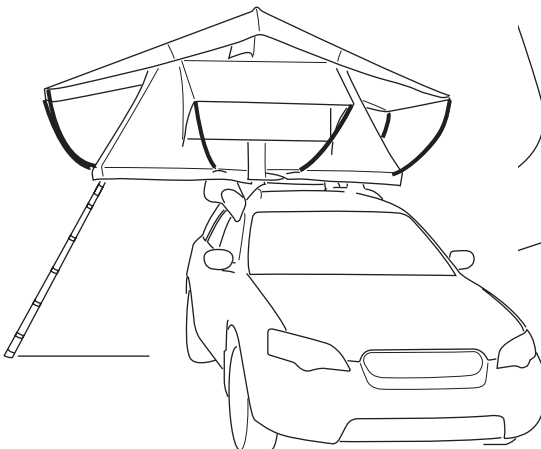

x8

# 3

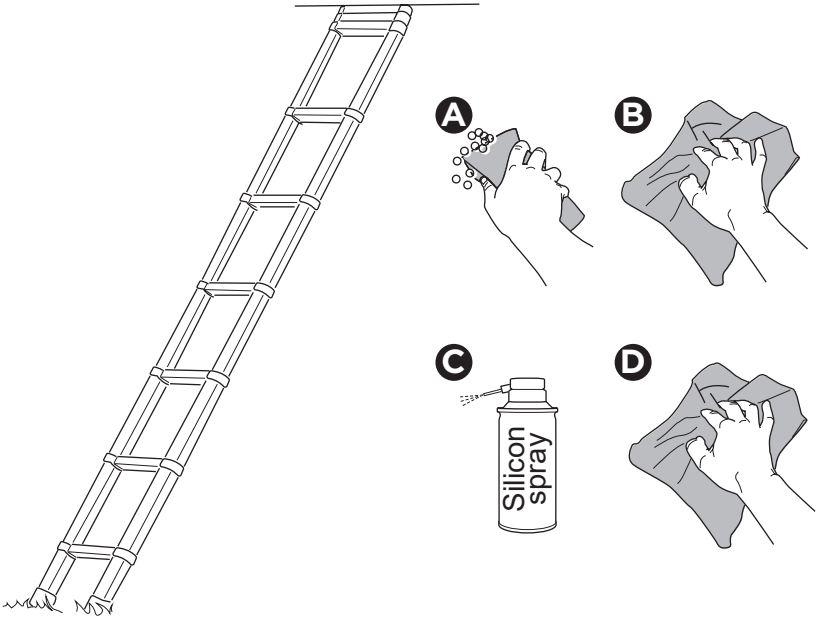

# 4

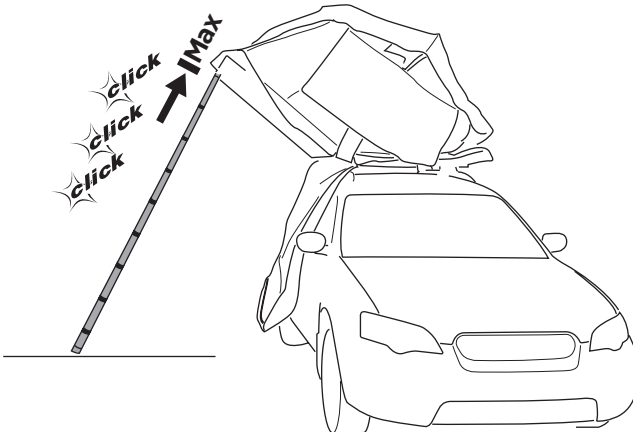

5

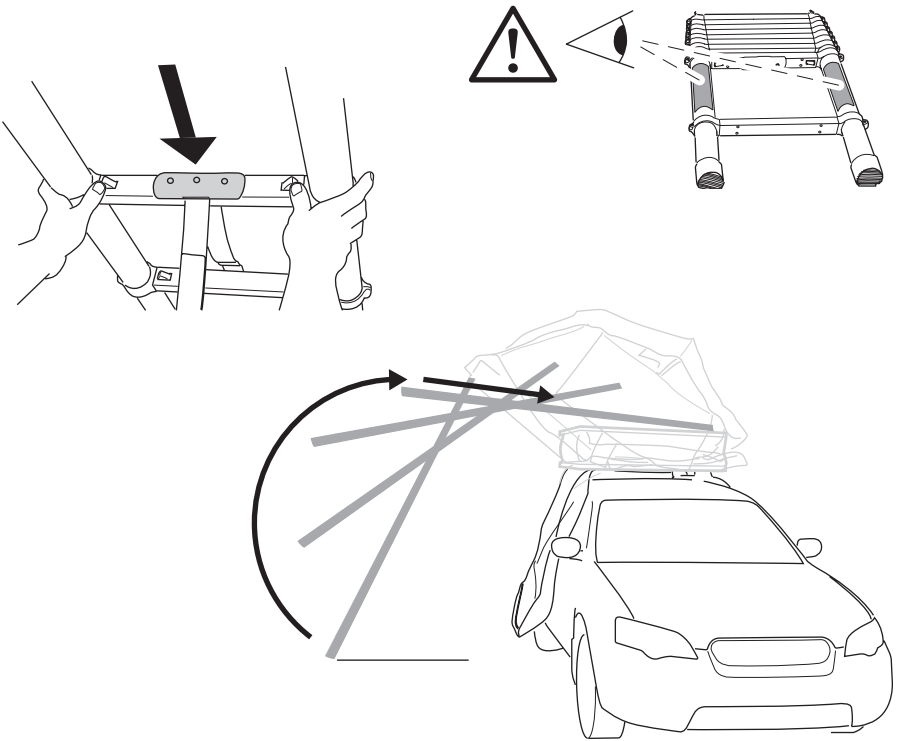

6

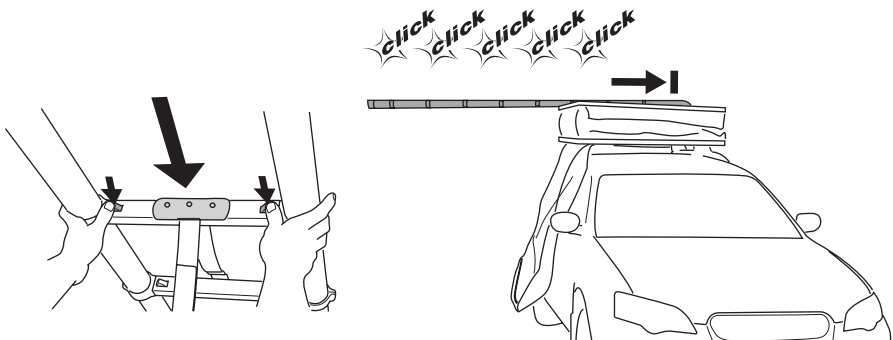

7

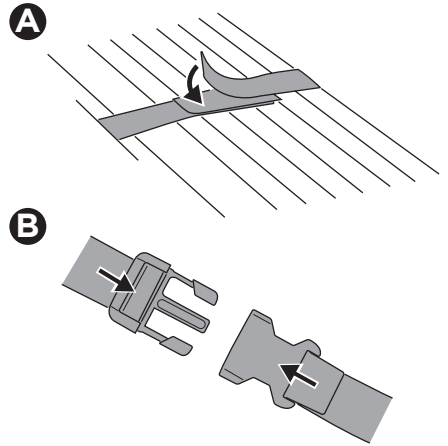
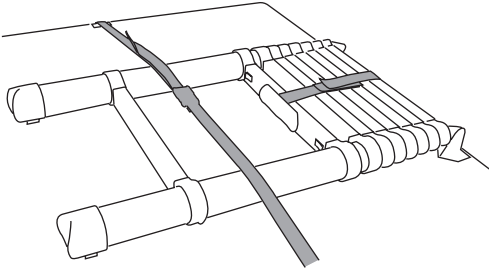

7

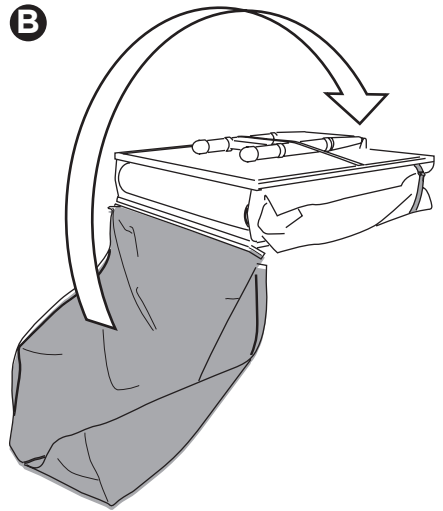
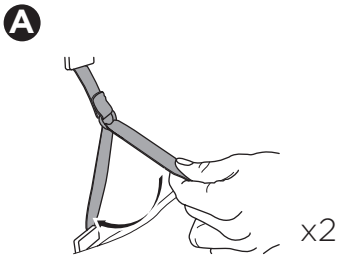

8

