

# ➤ Instructions

**Thule Tepui Autana 3**

**Thule Tepui Autana 4**

**Thule Tepui Ruggedized Autana 3**

901400, 901401, 901402, 901500, 901450, 901451



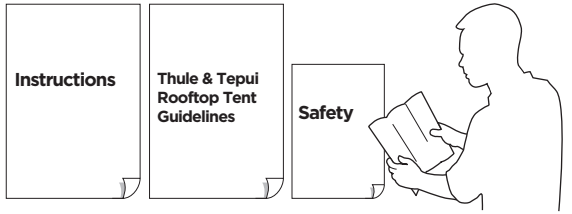

13 mm

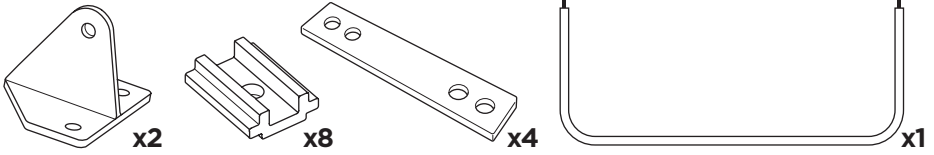
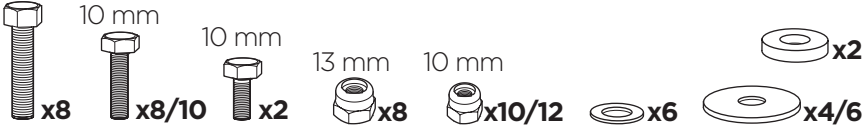

13 mm

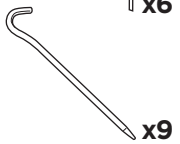
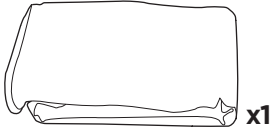
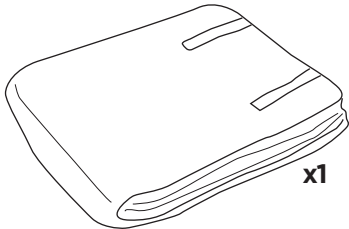
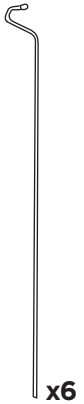
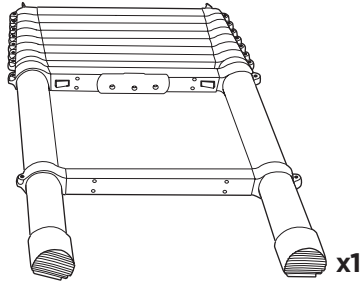
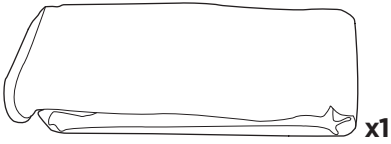
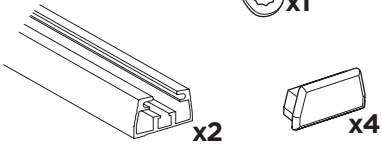
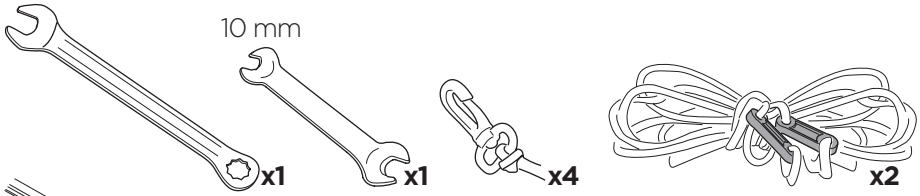

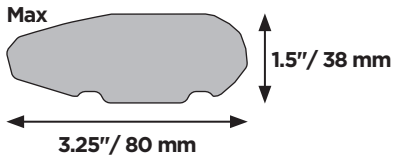

**Adapter** Thule Xsporter & Thule TracRac bar Xadapt 14

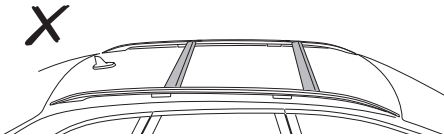
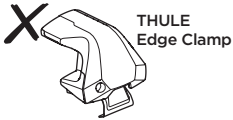
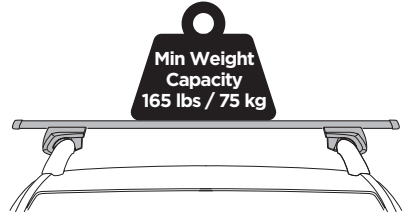
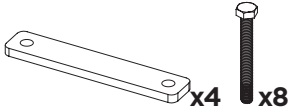

DO NOT use Tepui tents on factory installed crossbars.

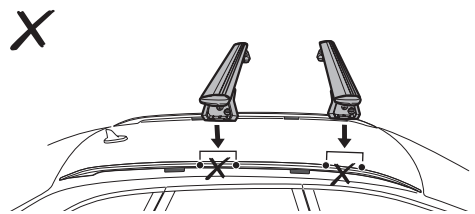
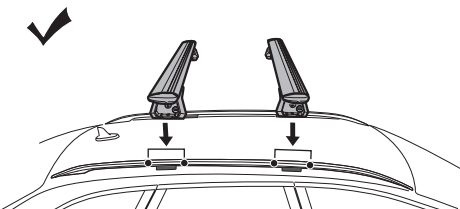
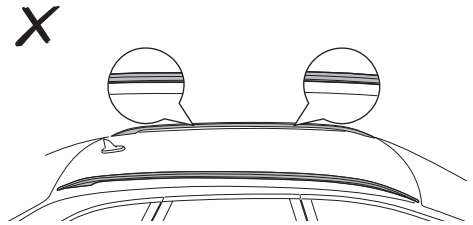
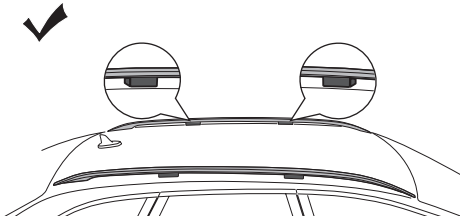
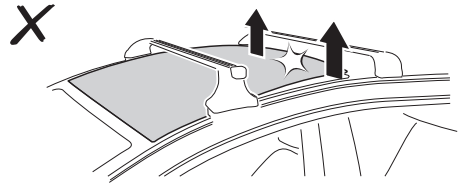

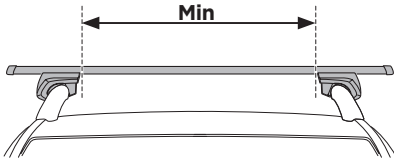

 **Min 33.5"/85 cm**

 **Min 30.7"/78 cm**

 **THULE SquareBar Evo Max 50"/127 cm**

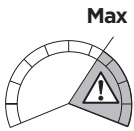

**Max 130 km/h  
80 Mph**

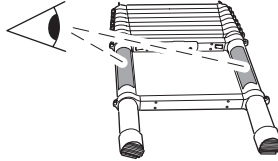

**136 kg  
300 lbs**

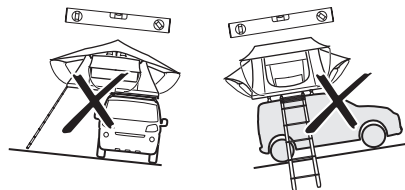
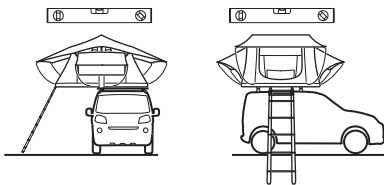
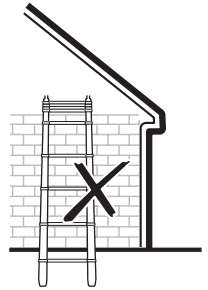
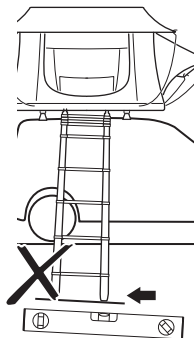
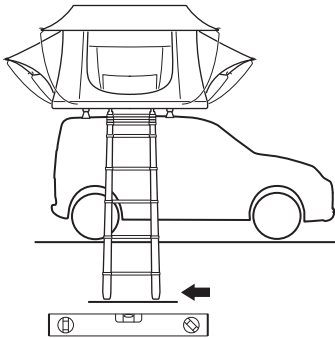
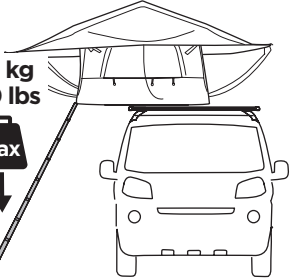

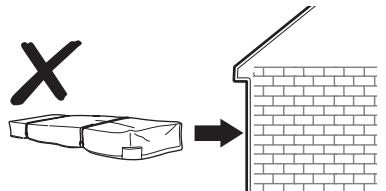
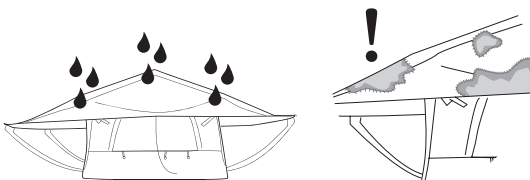
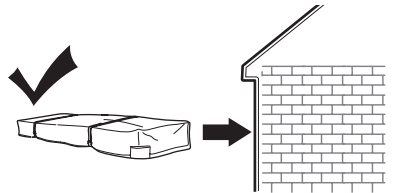
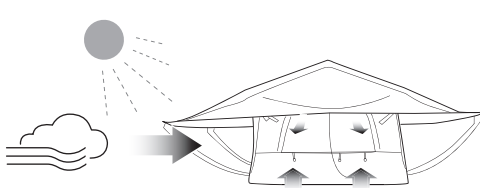
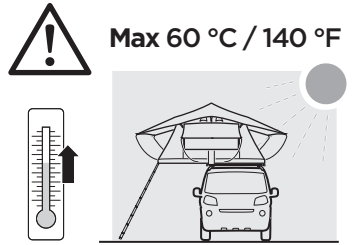
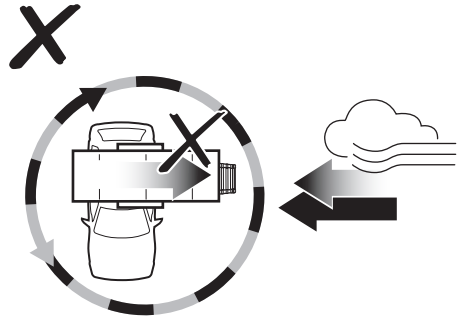
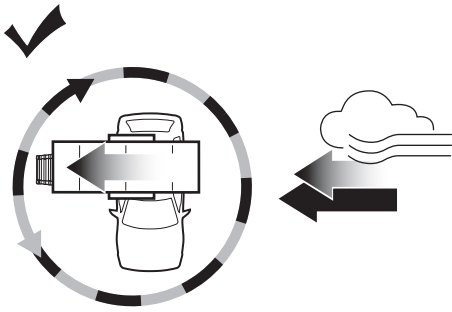

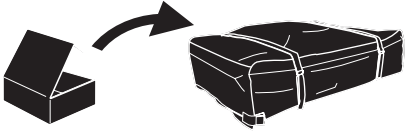

1

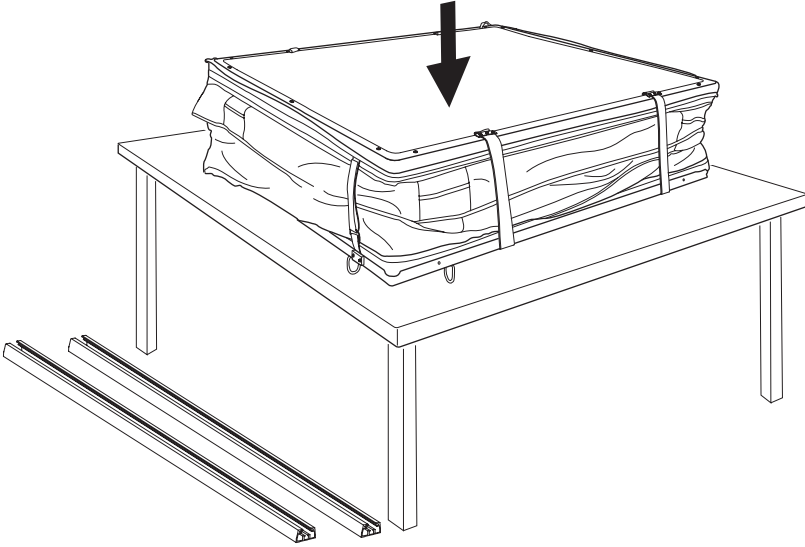

2

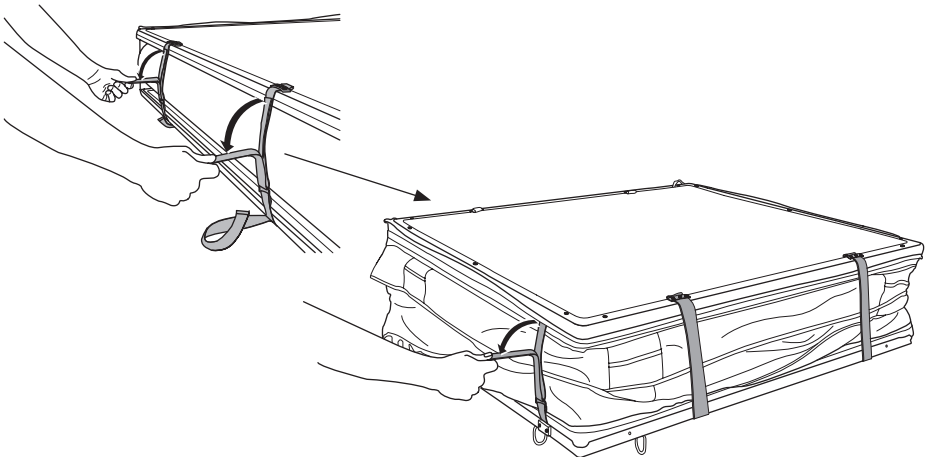

3

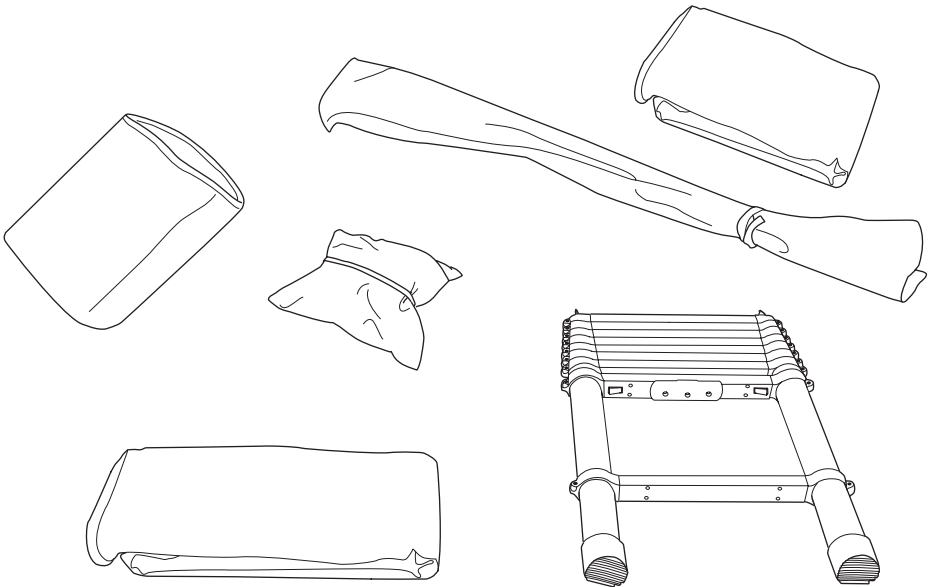
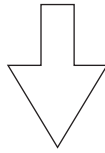
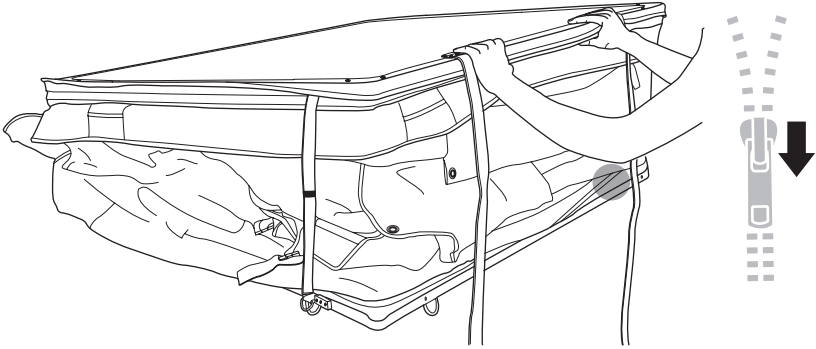

**i**

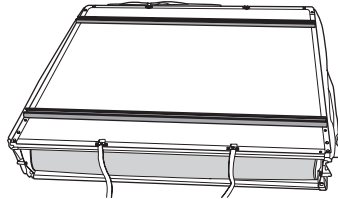
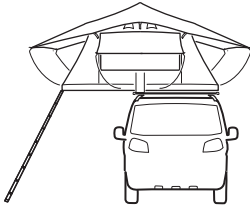
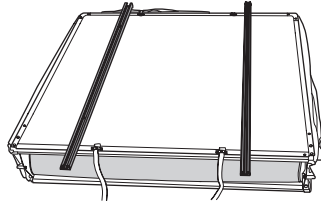
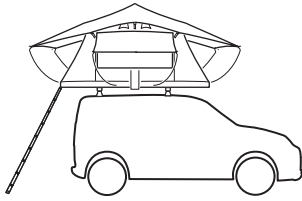

**4**

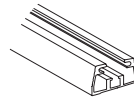

10 mm

x2



x4/6

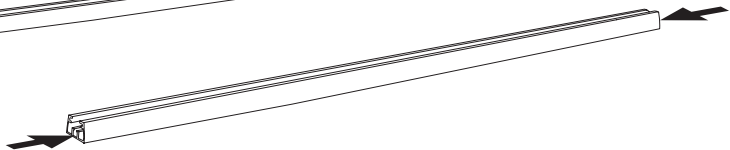
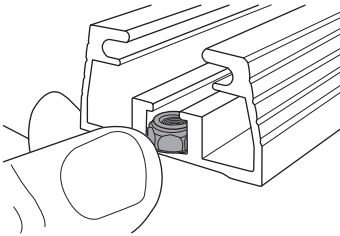



5

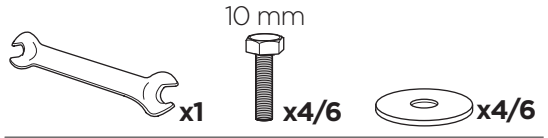

A

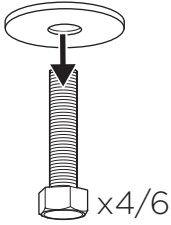

B

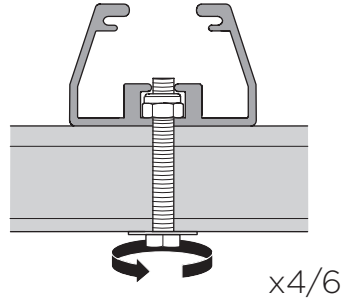
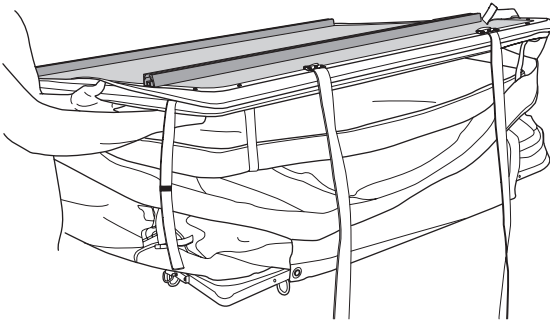

i

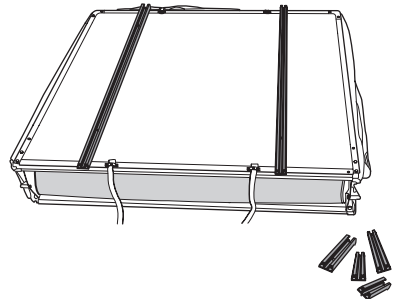
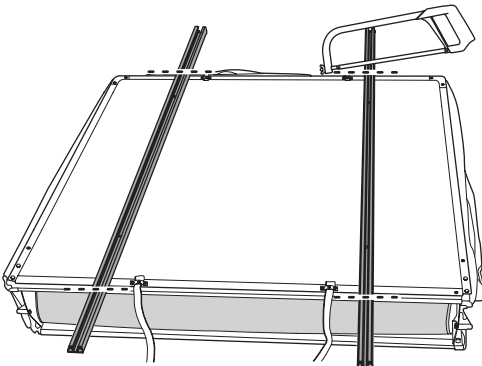
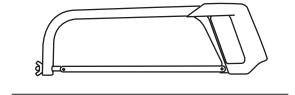
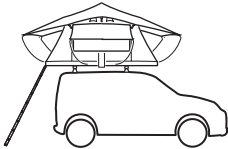

6

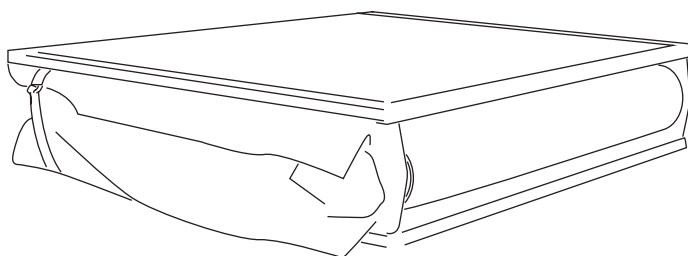
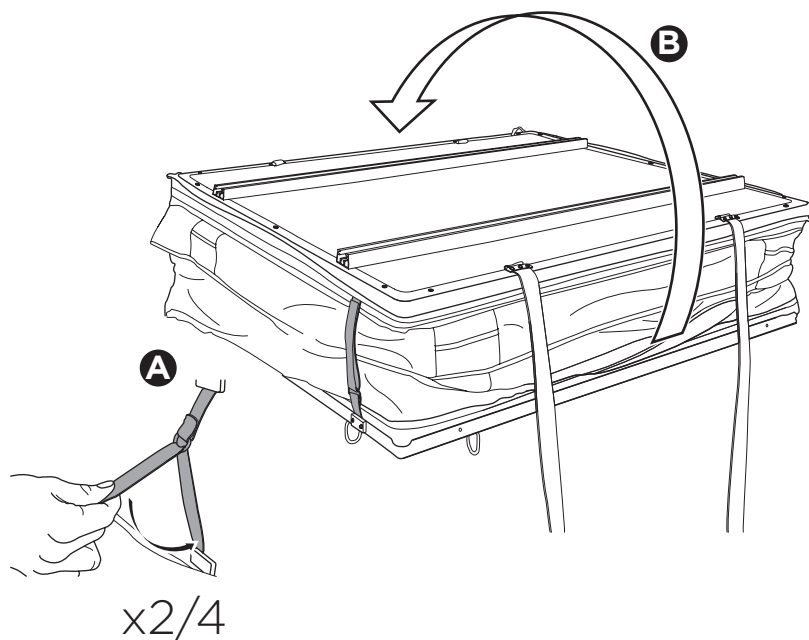

7

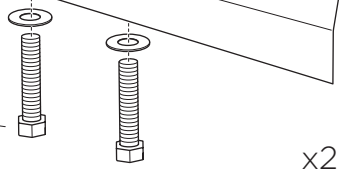
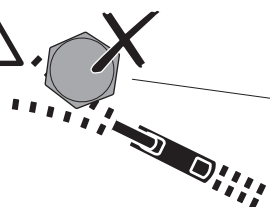
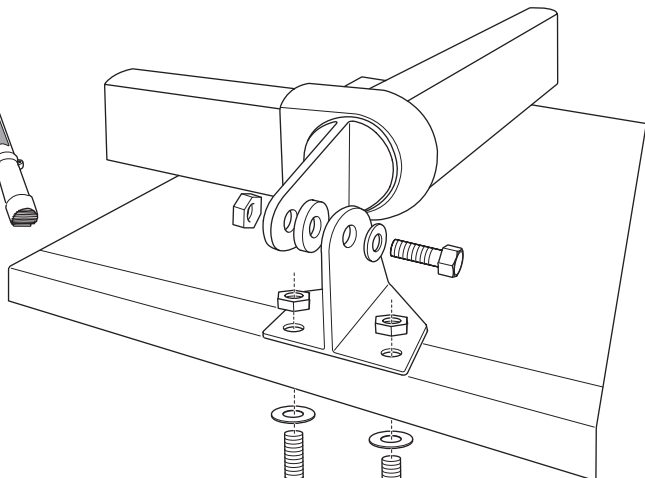
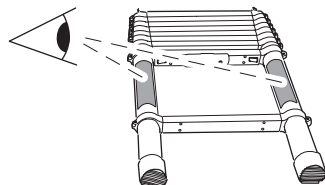
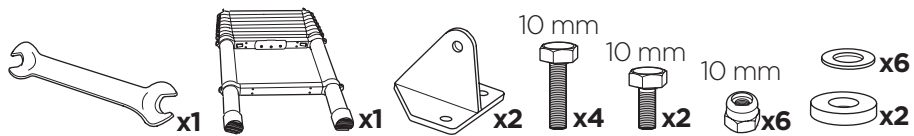

8

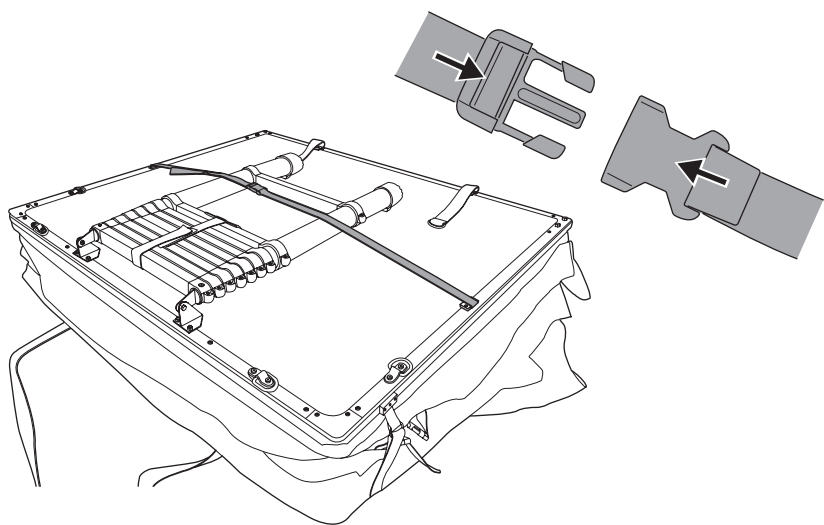

9

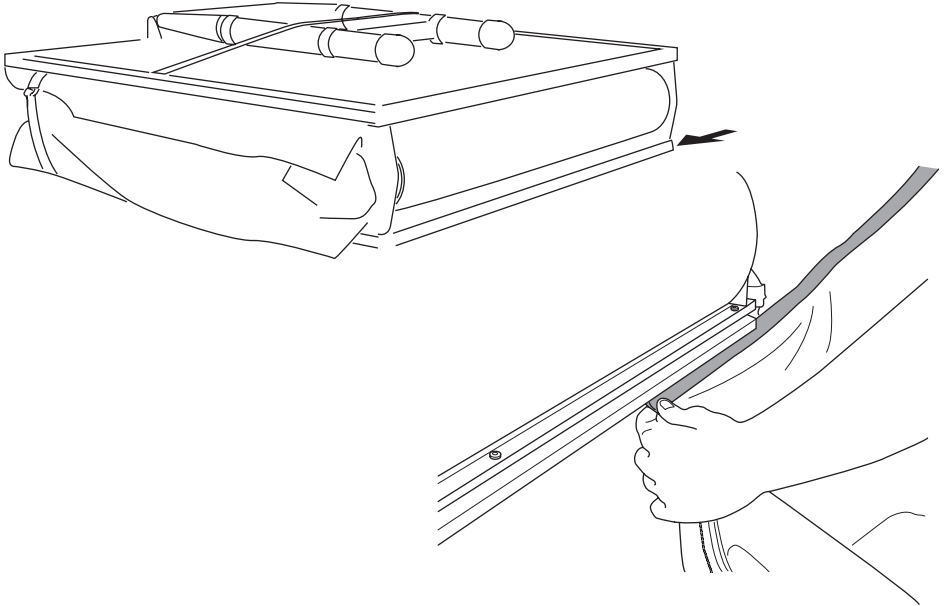
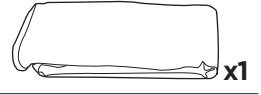

10

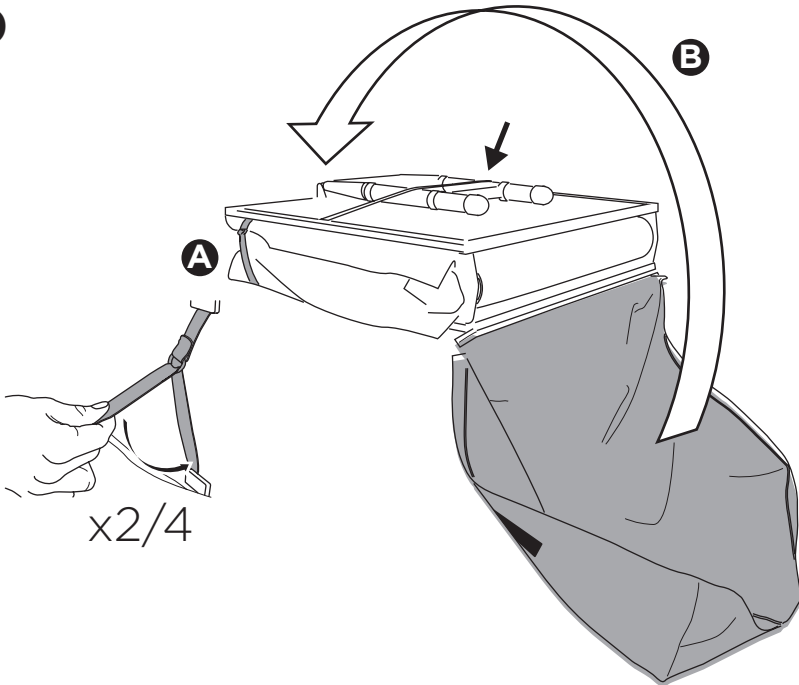

11

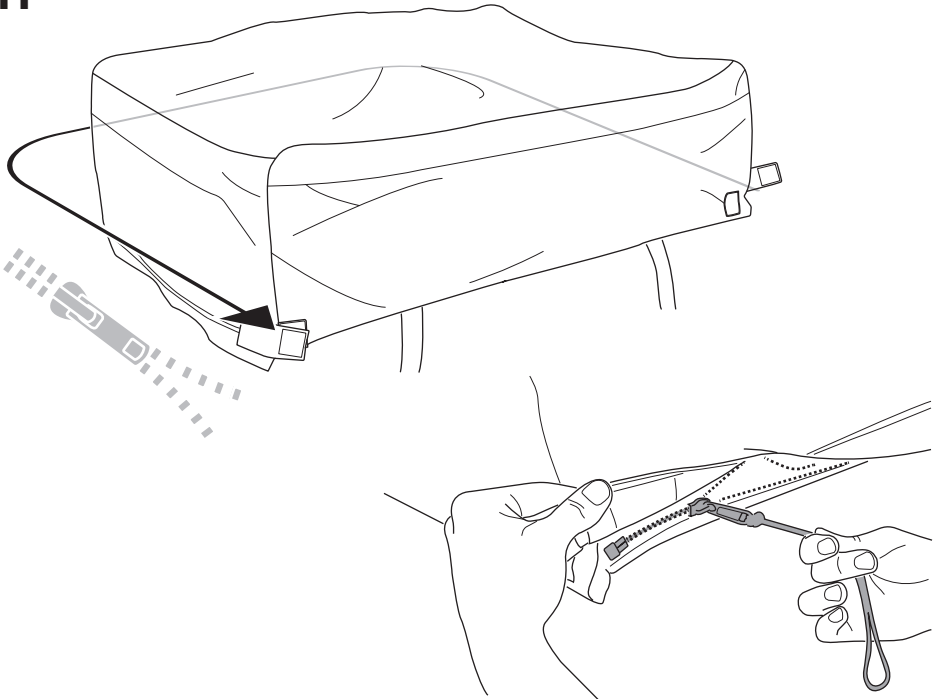

12

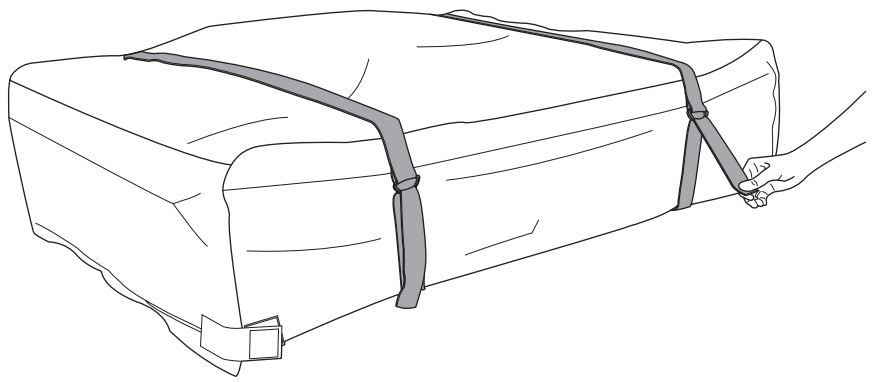

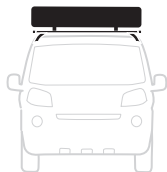

1

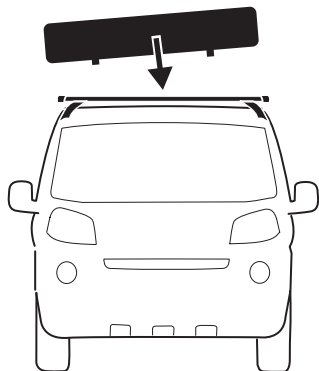

i

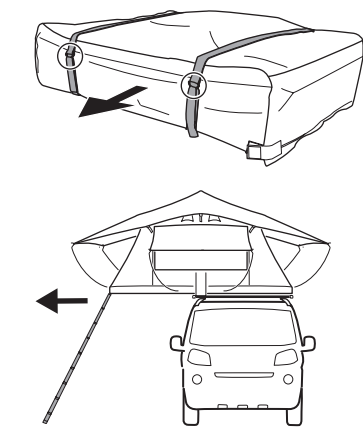

2

13 mm



x8



x8

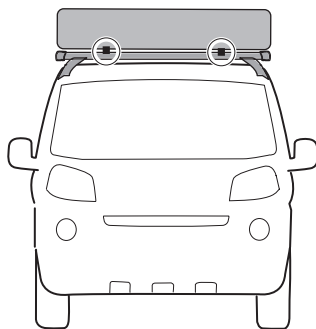
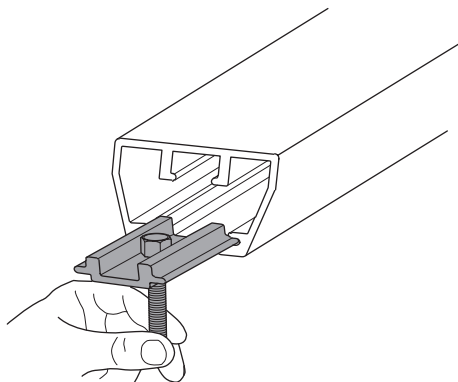

x8

3

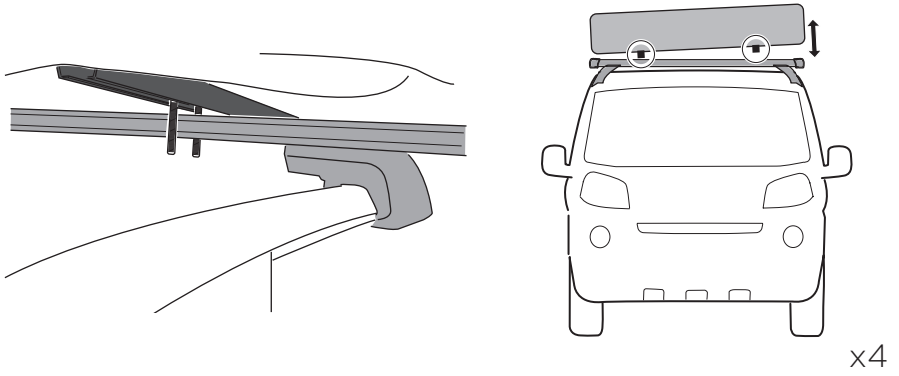

4

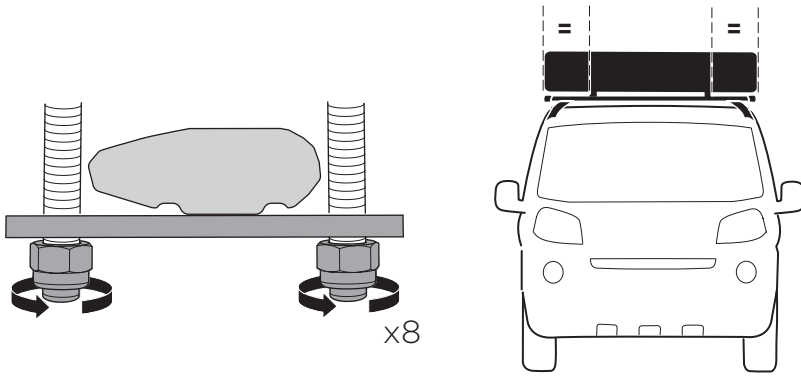

5

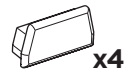
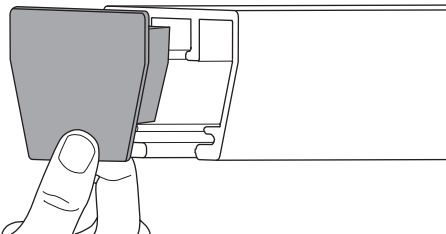

x4

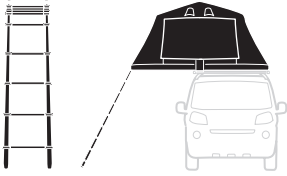

1

A

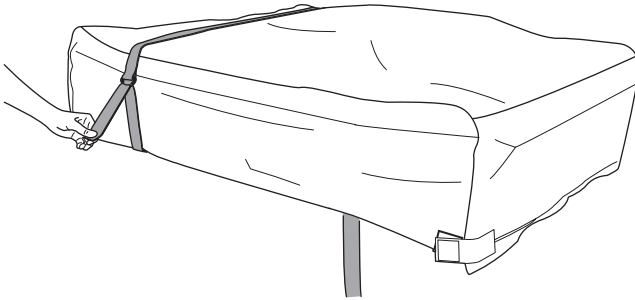

B

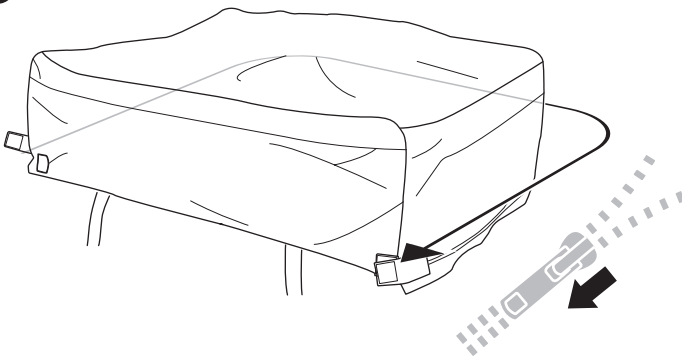



2

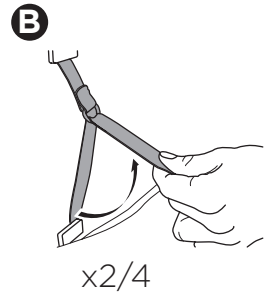
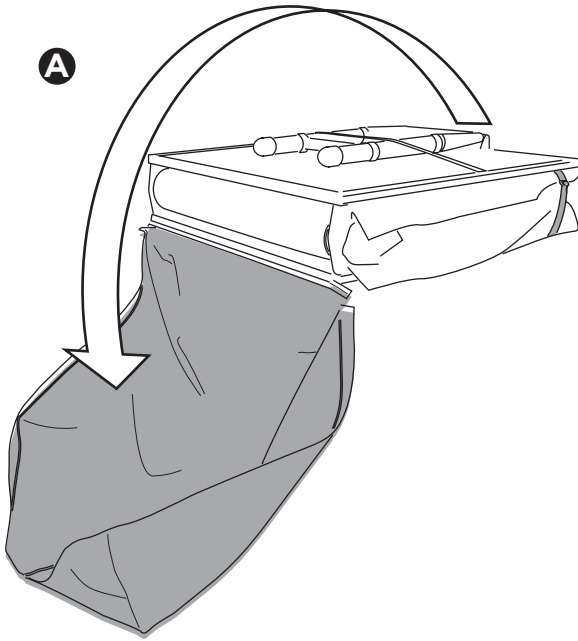

3

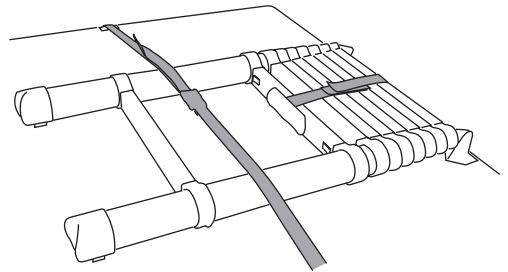
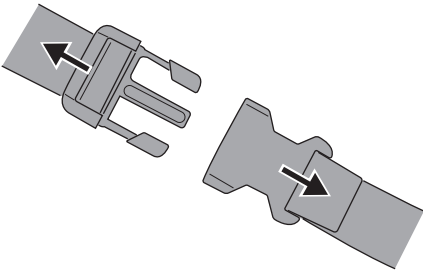

4

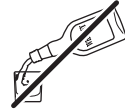
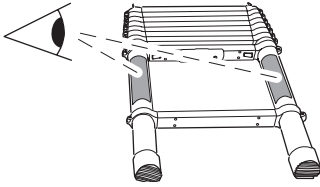

*click click click click click*

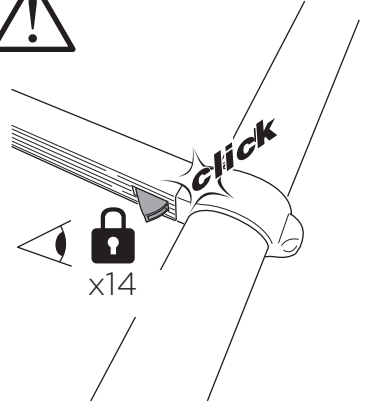
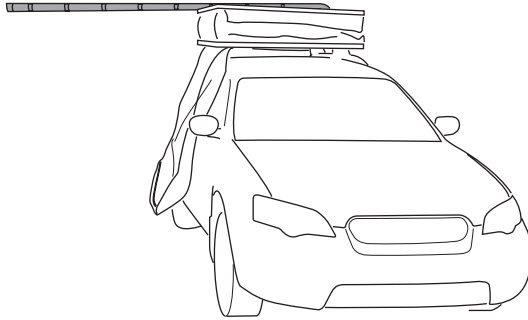

5

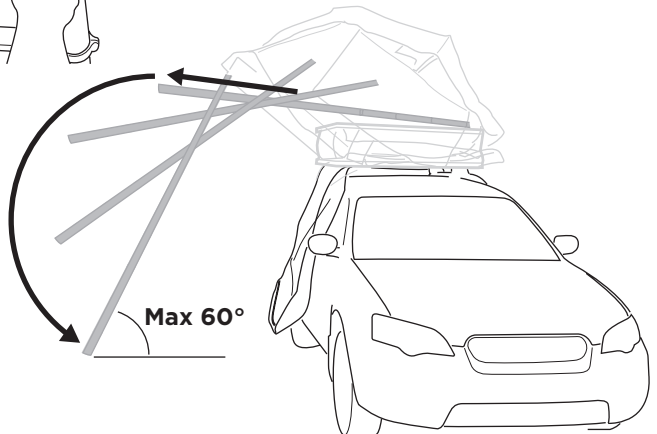
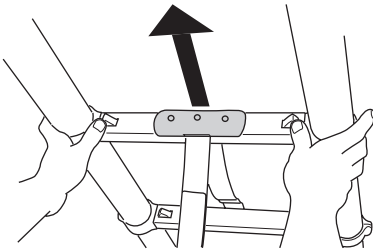

# 6

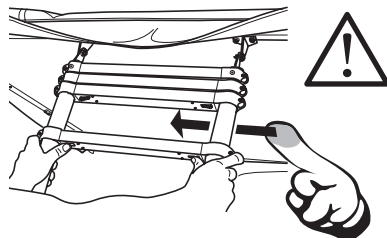
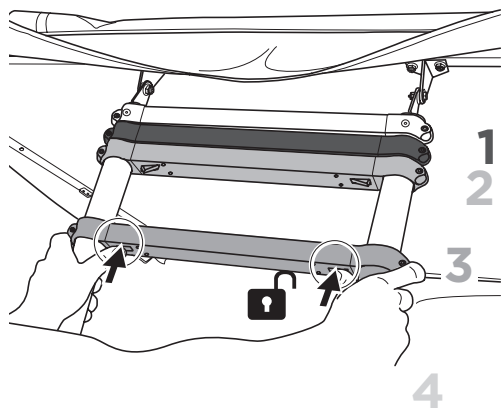
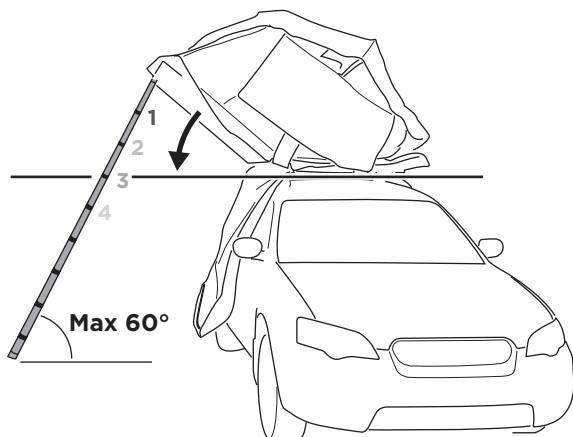

7

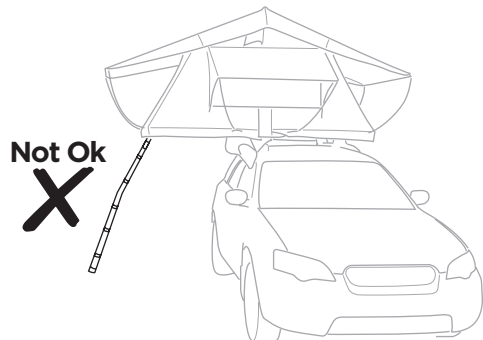
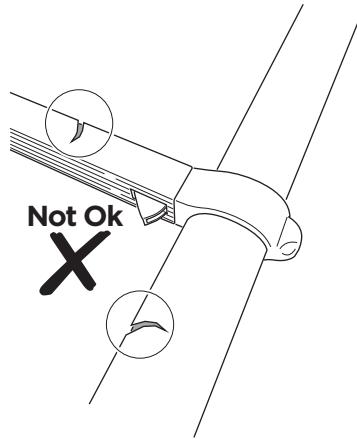
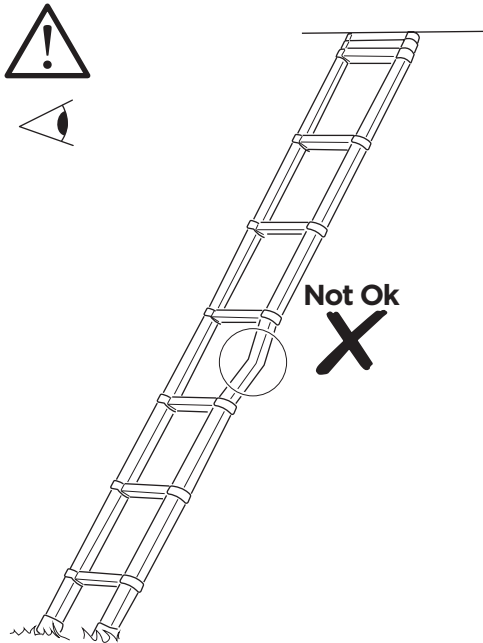
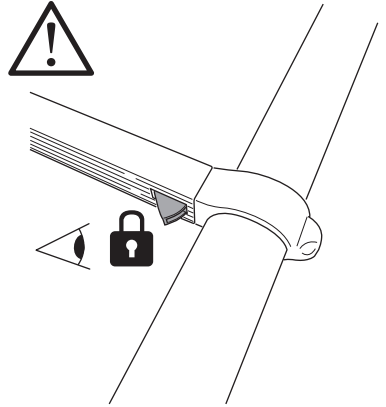
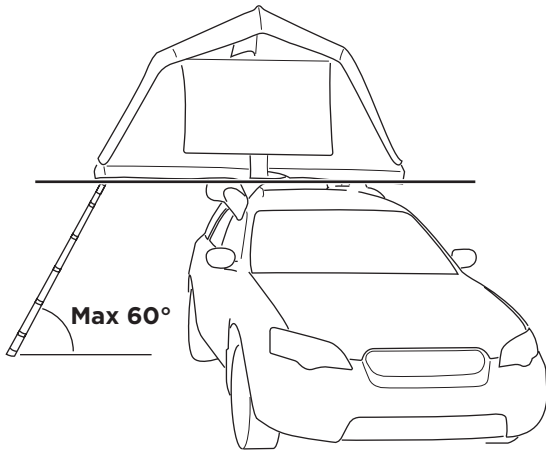

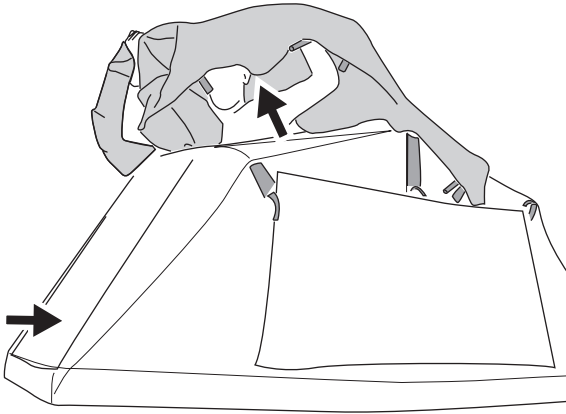
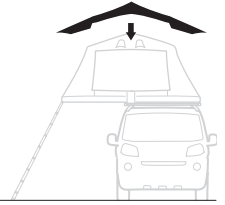

**A**

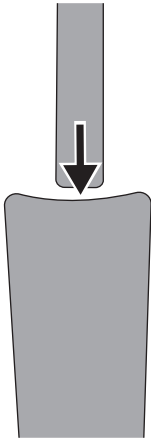

x6

**B**

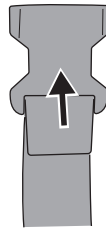
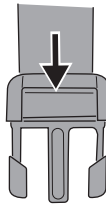

x6

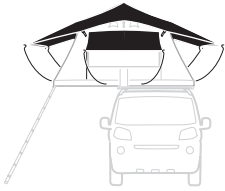

1

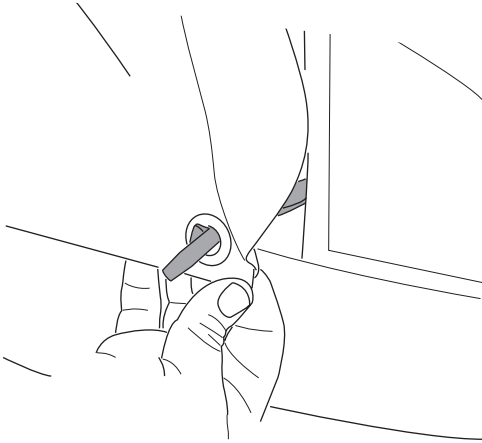

2

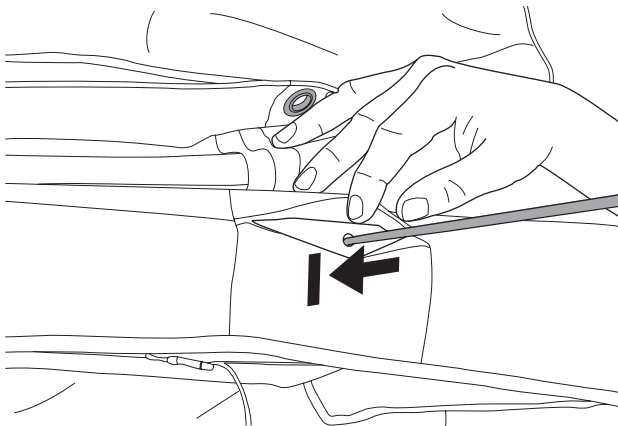

x6

3

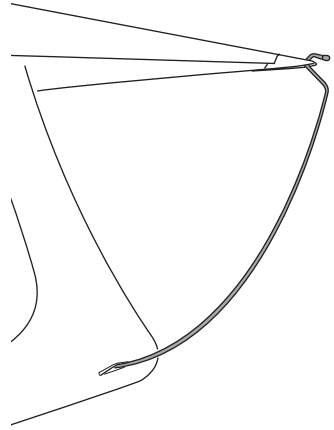
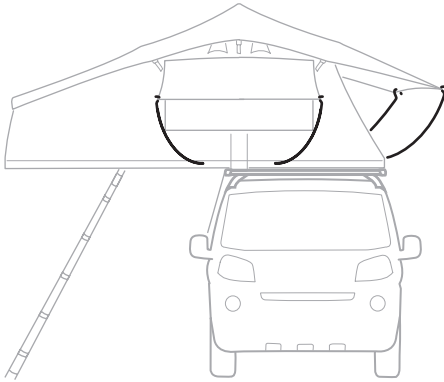

4

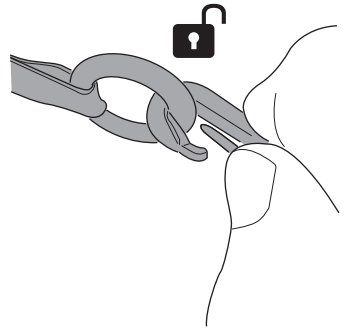
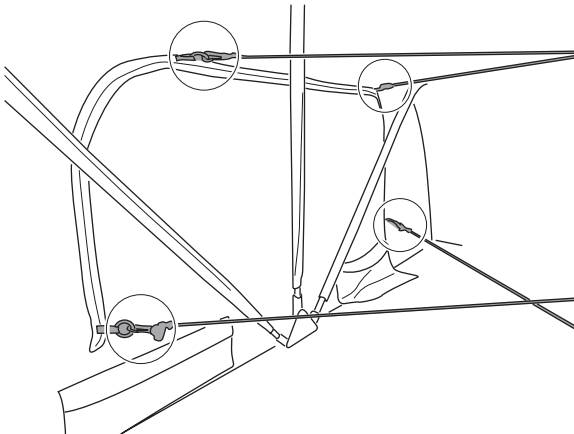

x8

**i**

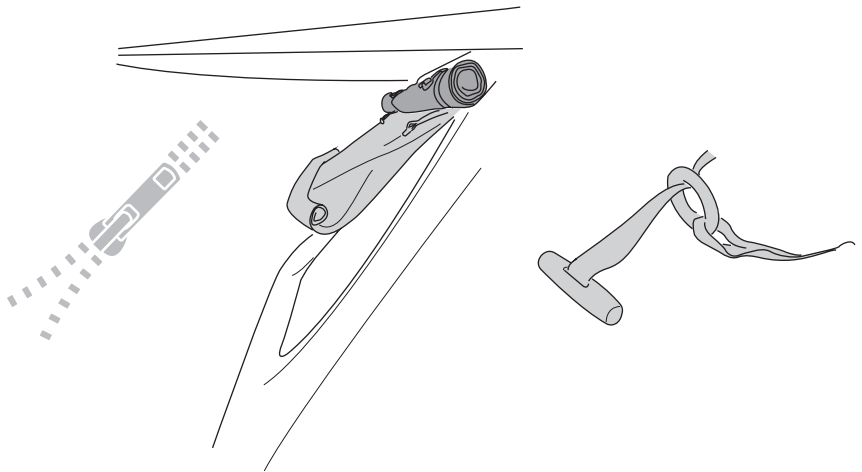
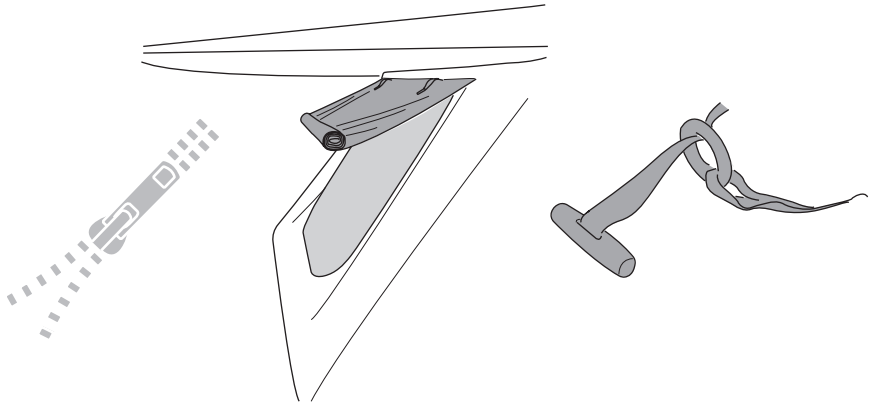



**i**

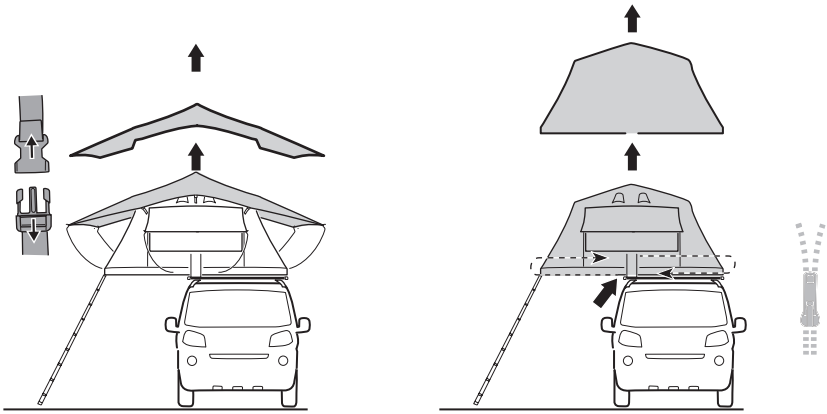

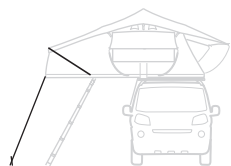

1

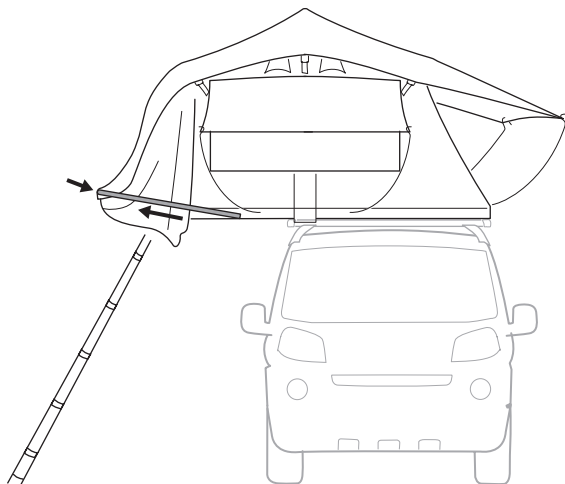

2

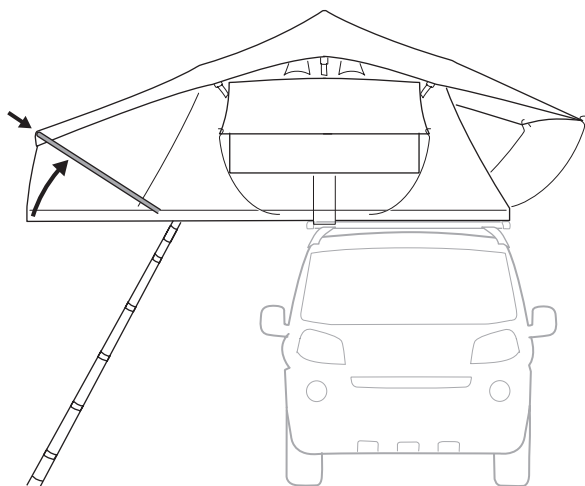

3

A

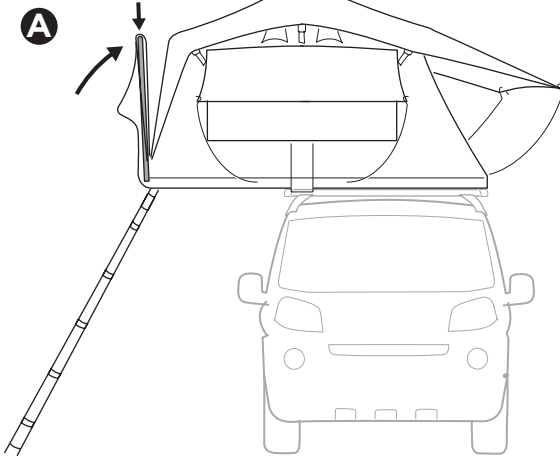

B

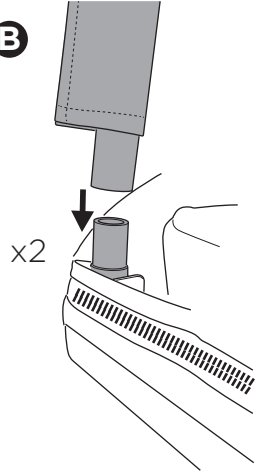

4

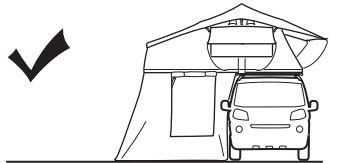
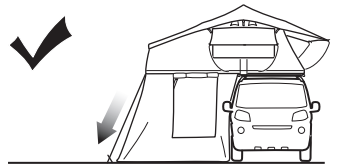
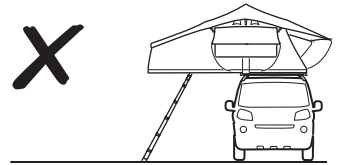
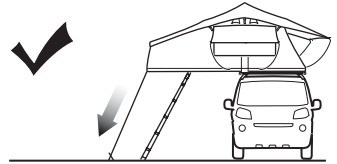
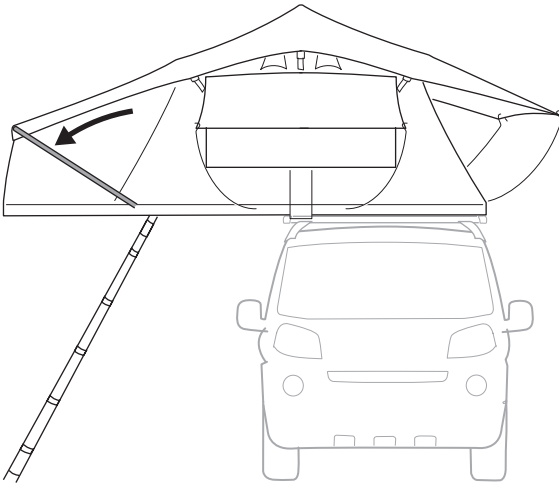

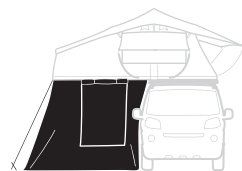

**1**

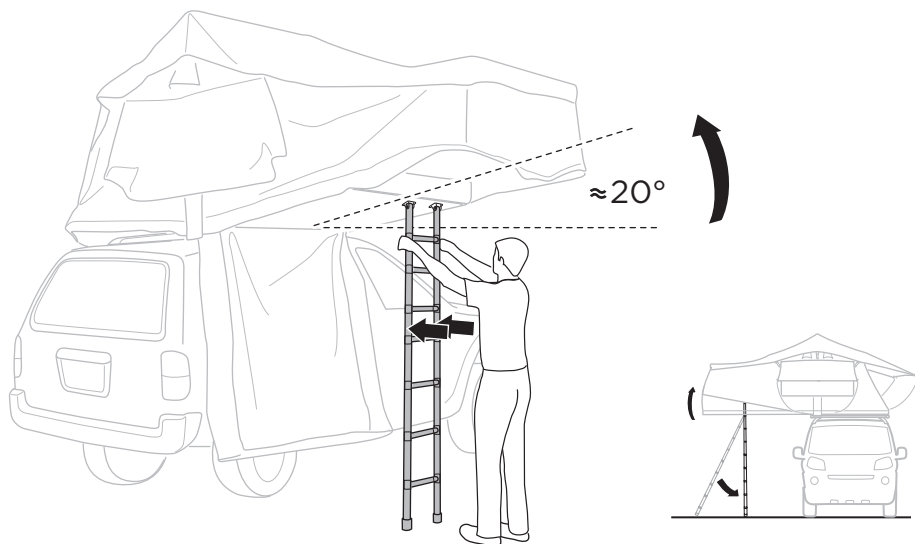

**2**

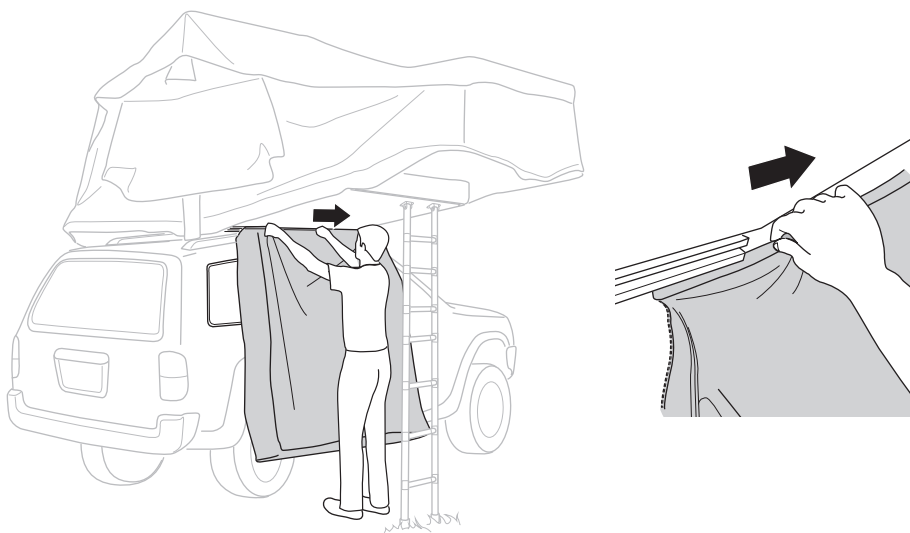

3

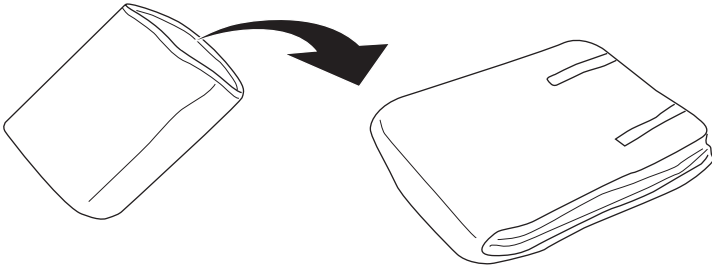

4

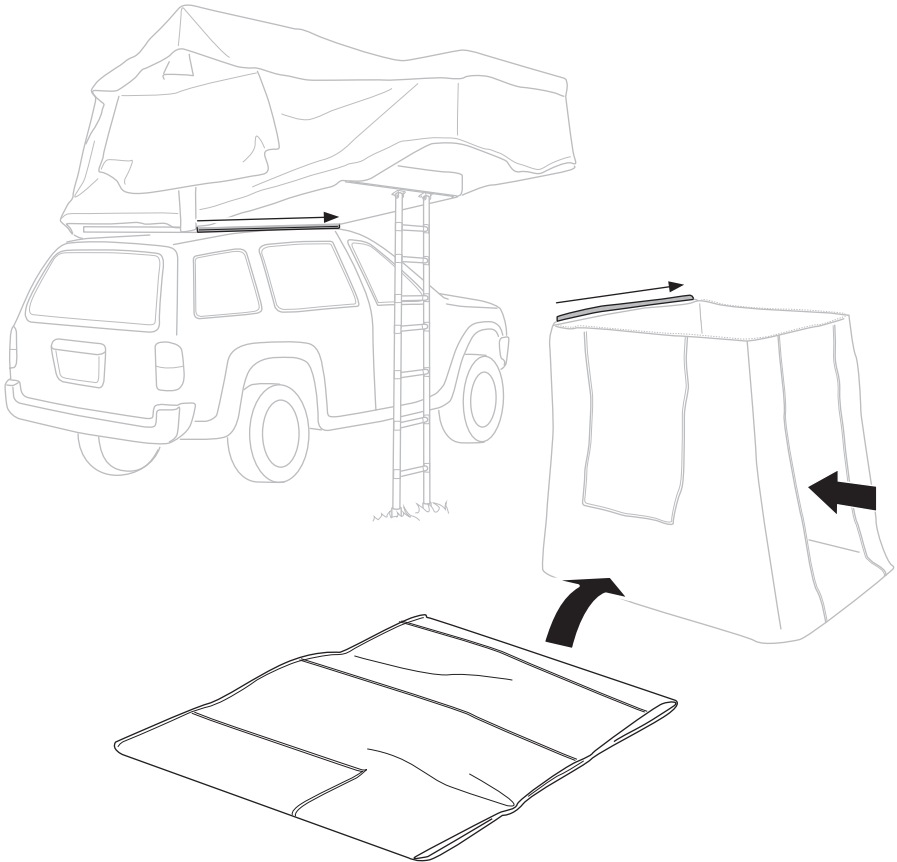

5

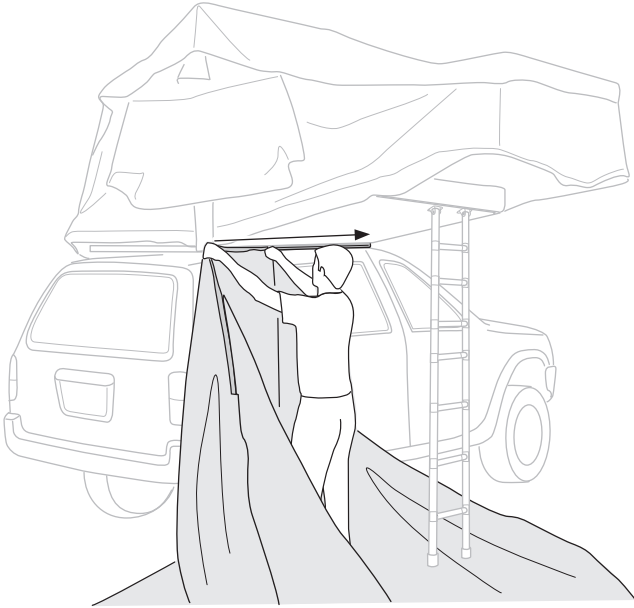

6

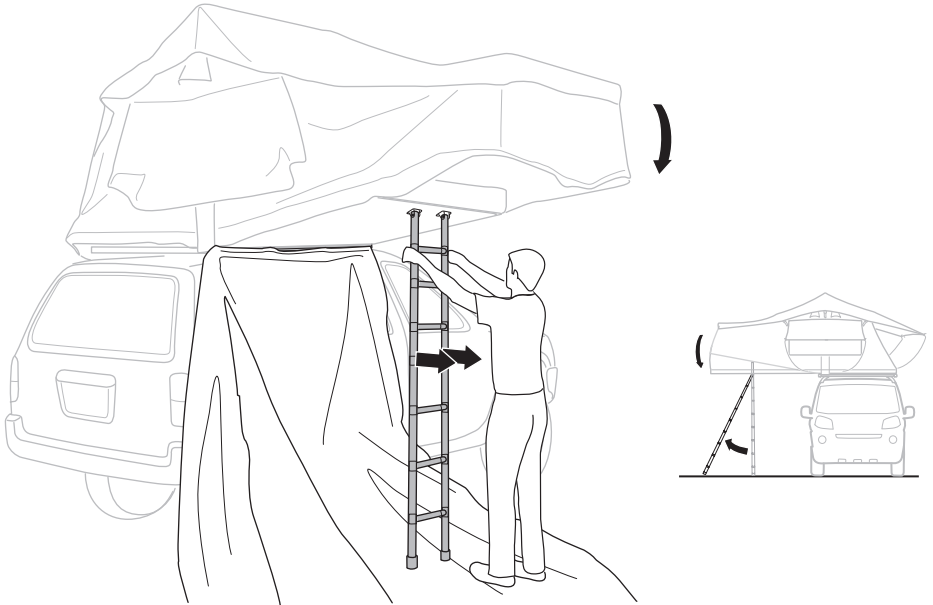

# 7

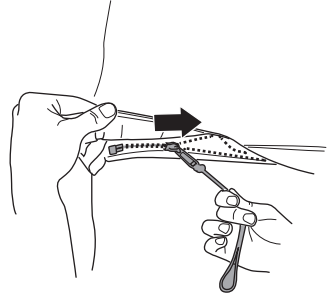
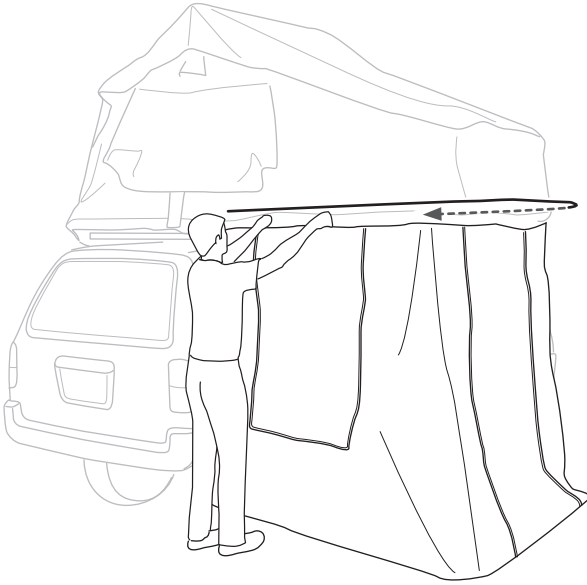

---

# 8

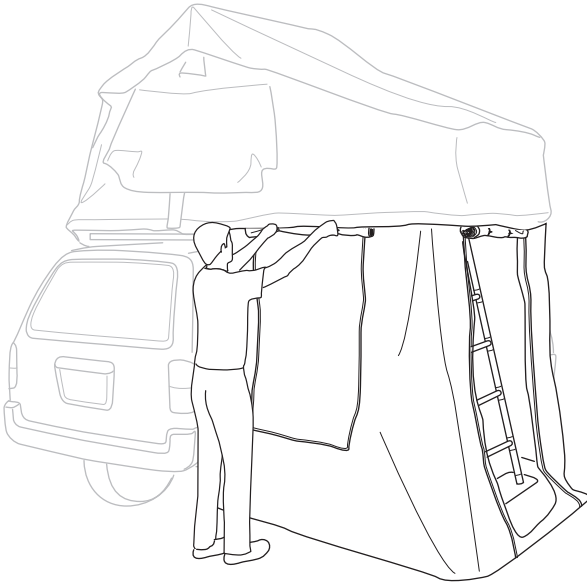

9

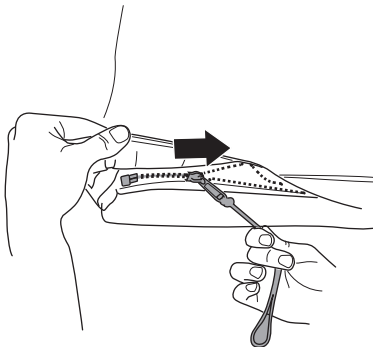
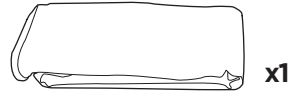



# 10

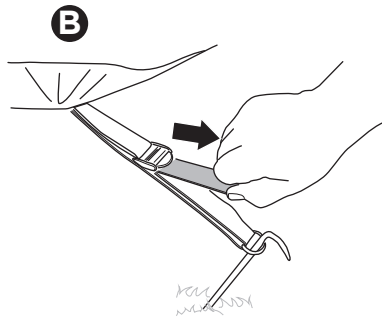
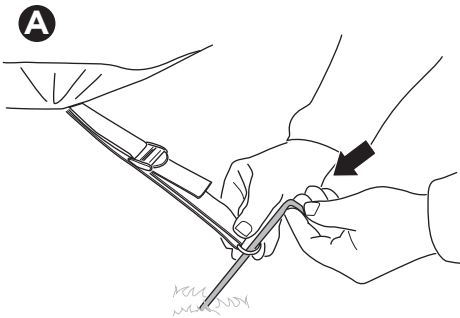



1

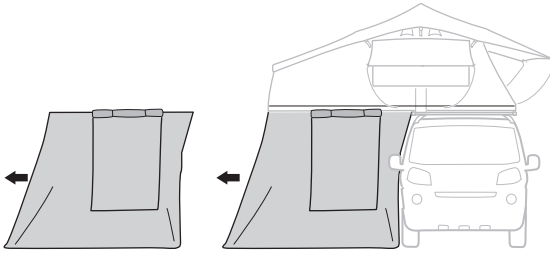
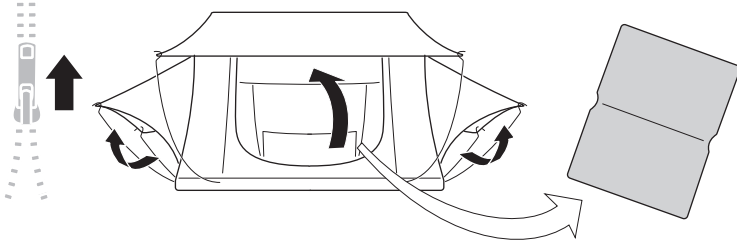

2

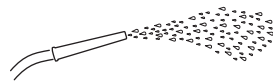
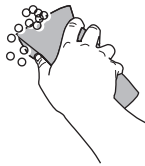

3

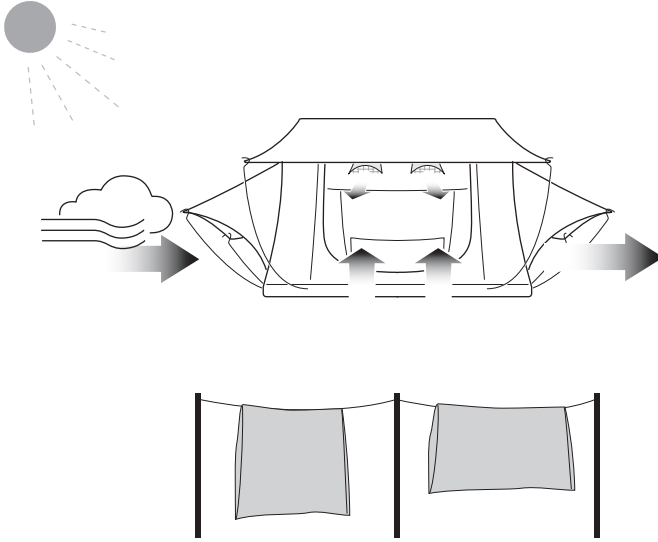

4

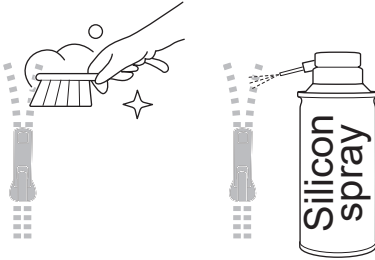



1

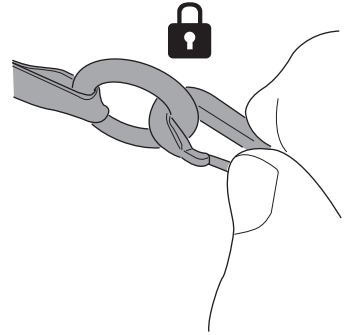
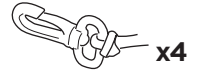
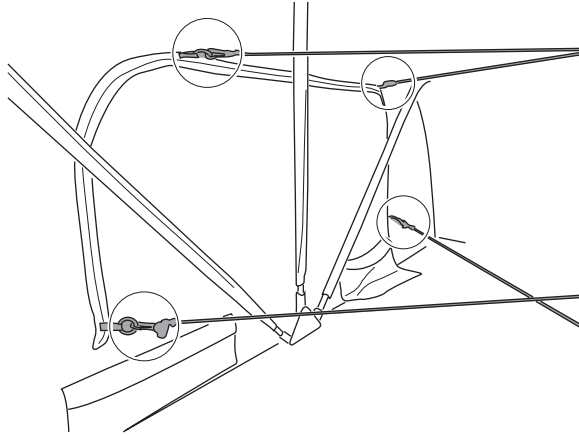

x8

2

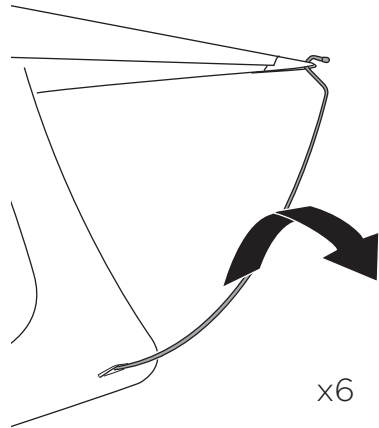
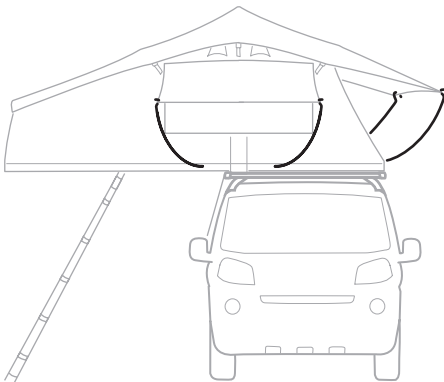

x6

# 3

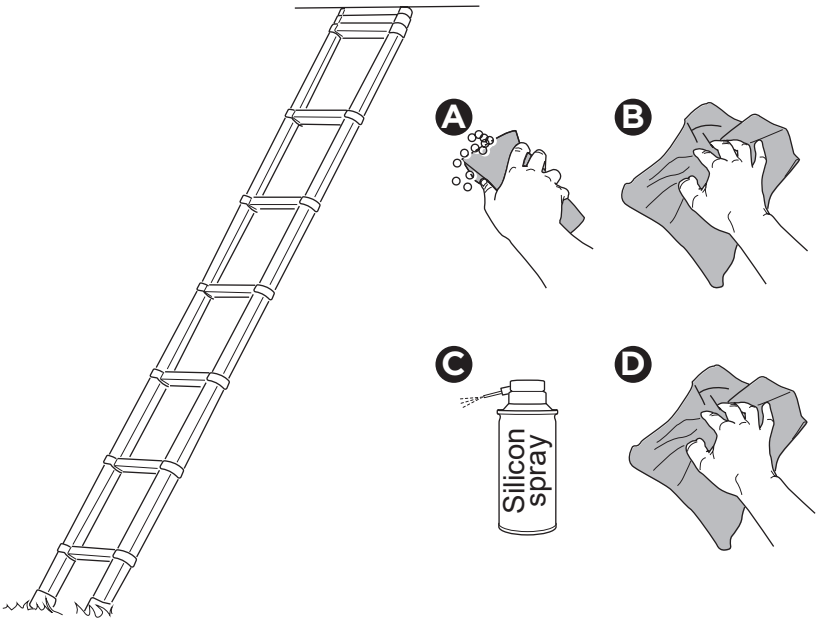

# 4

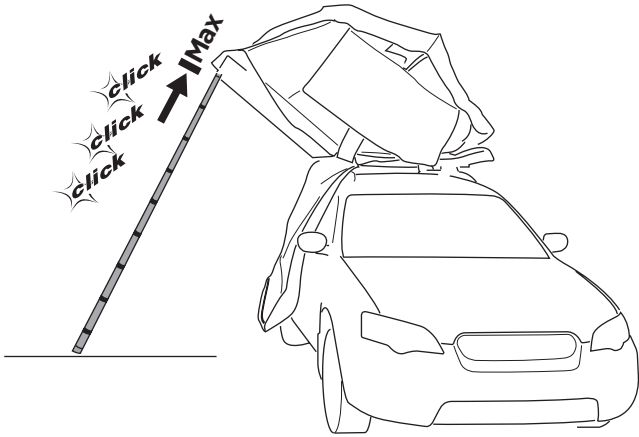

5

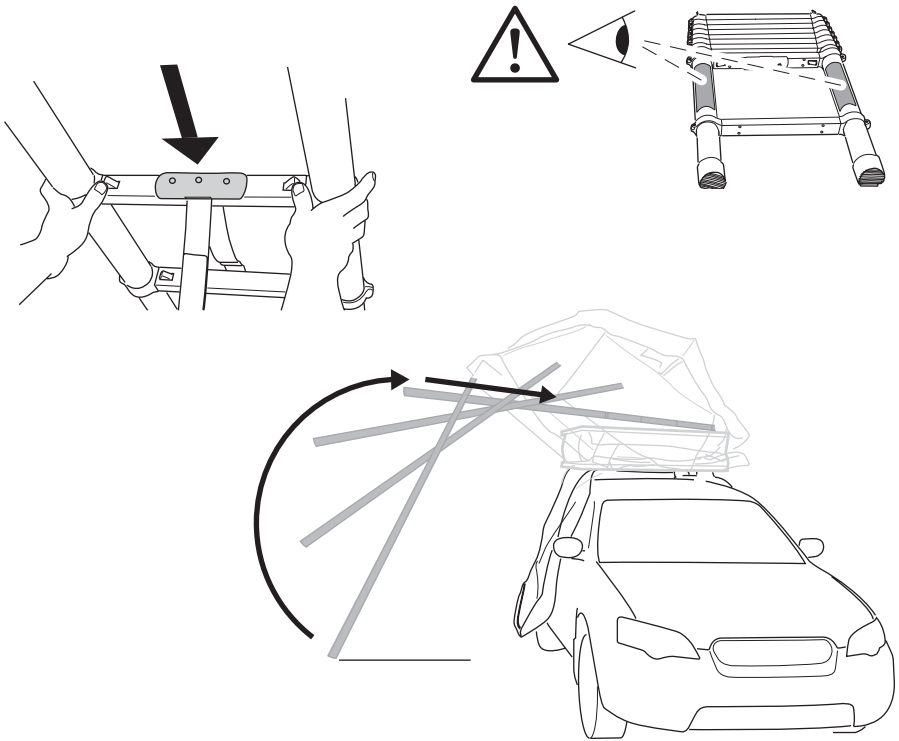

6

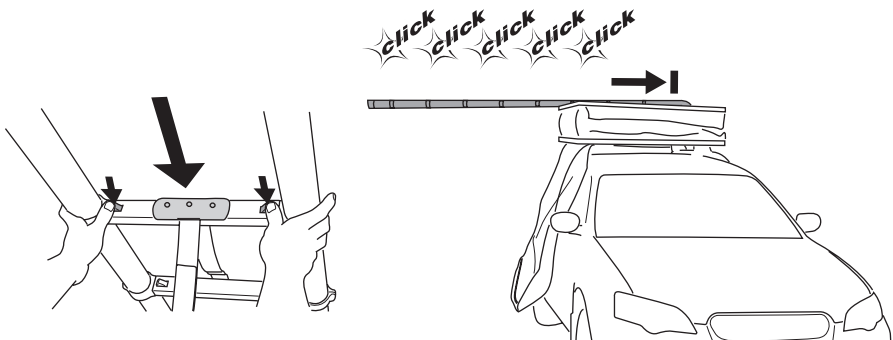

7

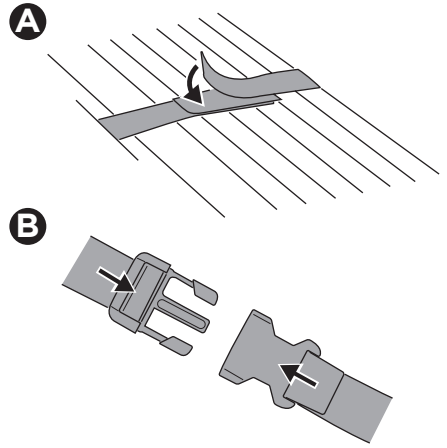
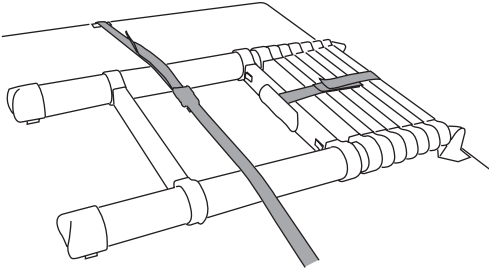

8

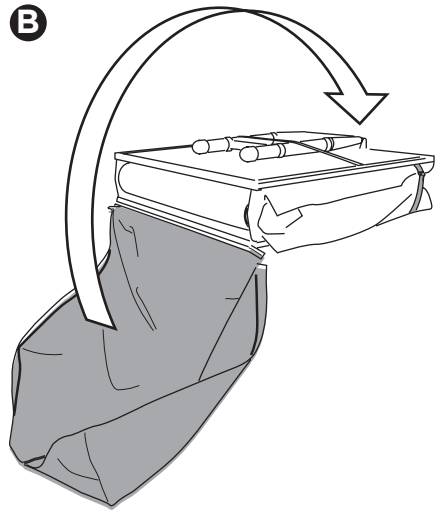
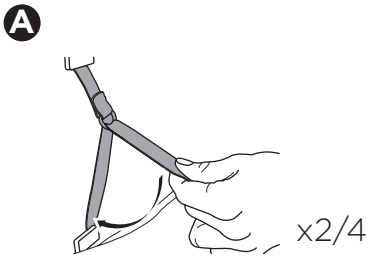

9

