

THULE®

SWEDEN

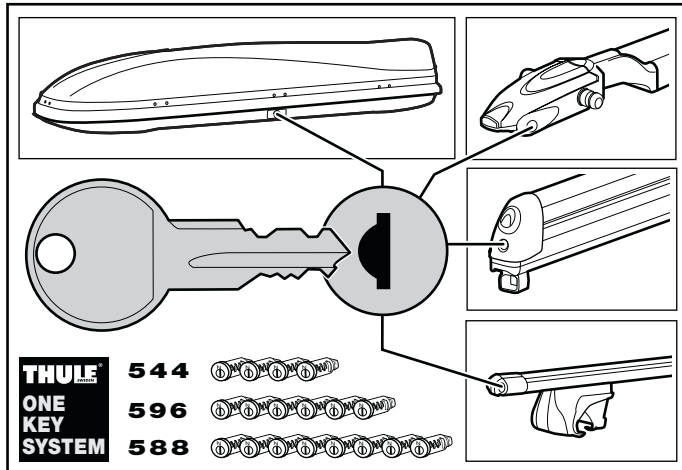
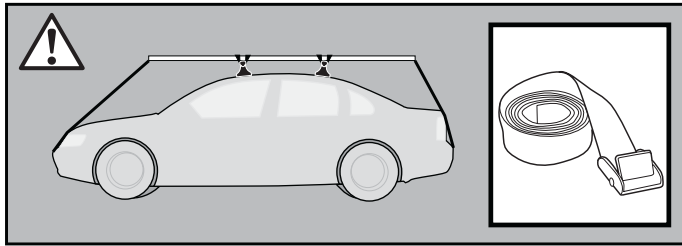
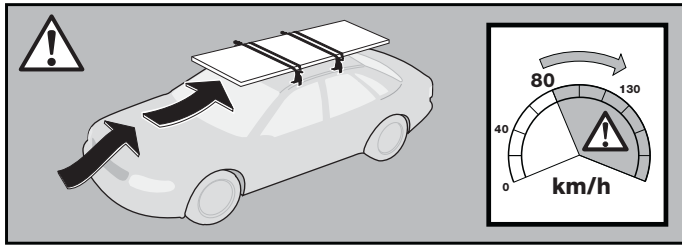
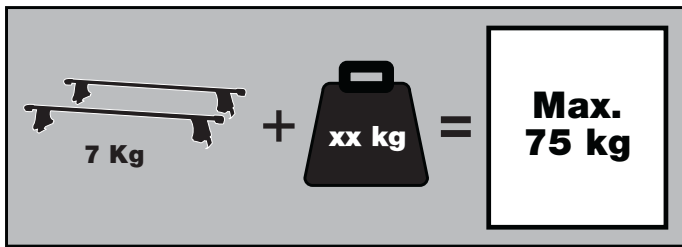

- S Monteringsanvisning
 - GB Fitting instructions
 - D Montageanleitung
 - F Instructions de montage
 - NL Montage-instructies
 - FIN Asennusohje
 - E Instrucciones de montaje
 - I Istruzioni per il montaggio
 - CZ Návod na montáž
 - PL Instrukcja montażu
 - HU Szerelési utasítások
 - RU Инструкции по установке
 - EST Paigalduseeskirjad
 - SLO Navodila za pritrjevanje
- 한국어 장착 지침
日本語 取扱(取付)説明書
中文 安装说明

VOLKSWAGEN Golf Plus, 5-dr Hatchback, 05

RAPID SYSTEM

Se não houver instruções no seu idioma, entre em contato com os funcionários do estabelecimento para obter informações

Αν οι οδηγίες δεν εκτυπώνονται στη γλώσσα σας, παρακαλούμε ζητήστε πληροφορίες από το προσωπικό του καταστήματος.

Eğer talimatlar dilinizde basılı değilse, lütfen atölye personelinden bilgi isteyiniz.

ถ้าไม่มีคำแนะนำในภาษาของคุณ โปรดติดต่อพนักงานในร้านเพื่อขอข้อมูล

Kit 1382



Follow me...

THULE®

SWEDEN

Box 69, 330 33 Hillerstorp, SWEDEN
www.thule.com

603•3DF/8F/501-1382-03



THULE
COPENHAGEN

S Säkerhetsföreskrifter
GB Security regulations
D Sicherheits-Vorschriften
F Instructions importantes
NL Waarschuwingsoverzichten
FIN Turvatoimintäsuojukset
E Reglas de seguridad
I Norme di sicurezza
CZ Npředpis na montáž
PL Wykazy bezpieczeństwa
PT Normas de segurança
GR Απαιτήσεις Ασφάλειας
TR Güvenlik Kuralları
HU Biztonsági előírások
RU Инструкция по безопасности
HR Pravila sigurnosti
EST Ohutusjuhised
LIT Saugumo taisyklės
LAT Drošības noteikumi
SLG Varnostni predpisi
KOR 주의 사항
THAI ข้อควรระวังในการติดตั้ง
中国 安装注意事项

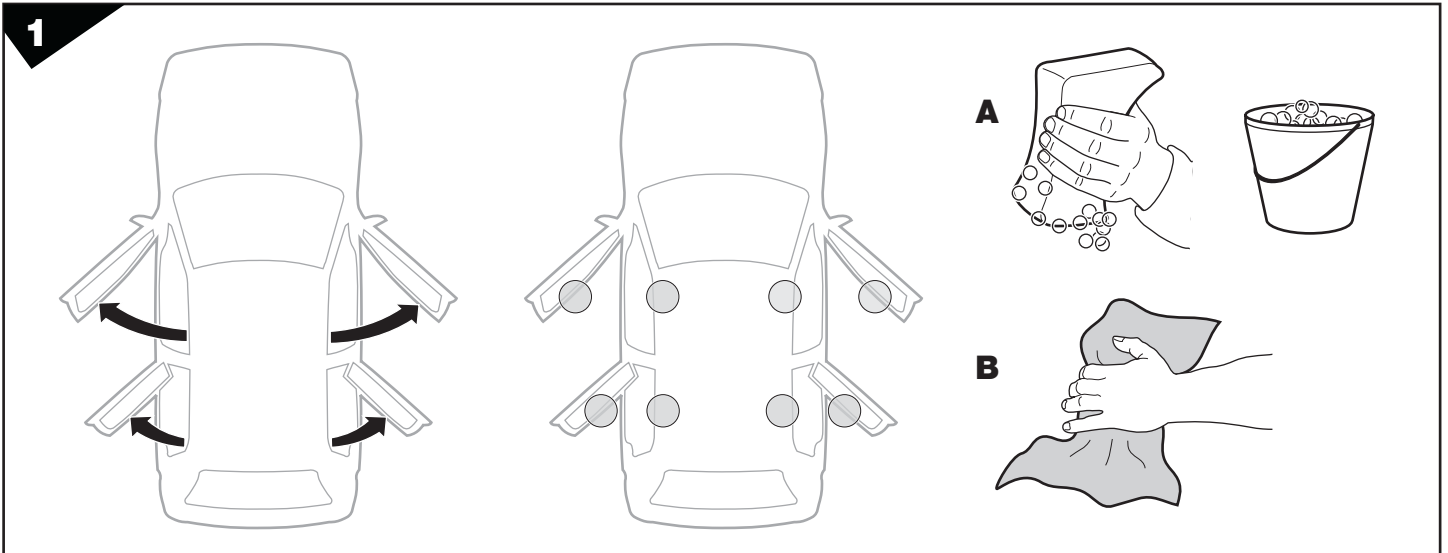
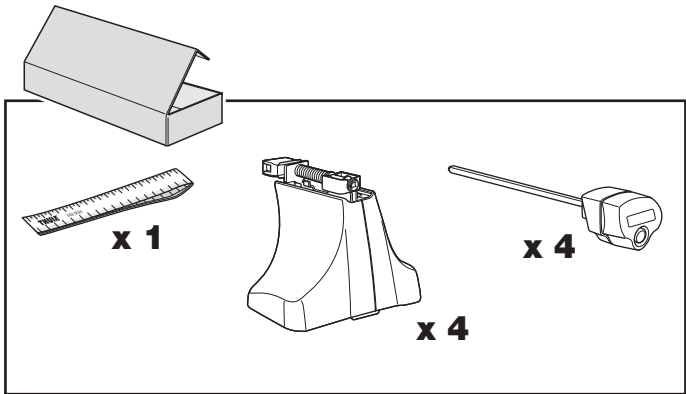
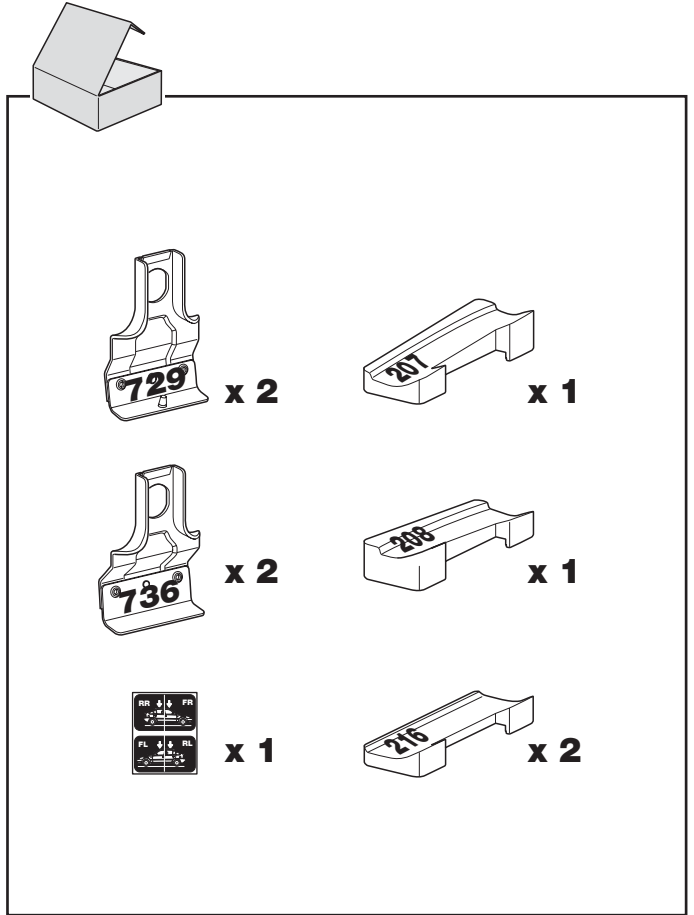
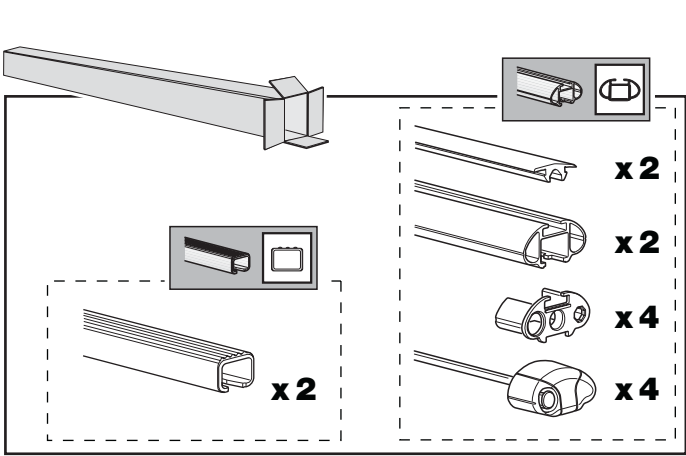
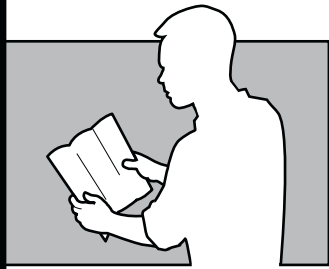

2

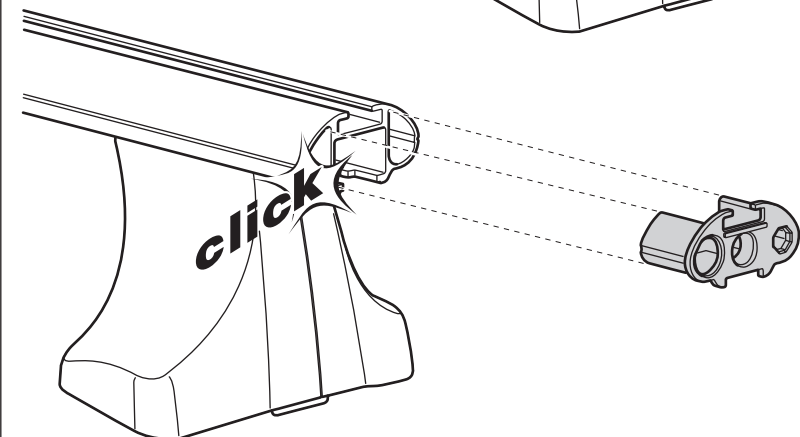
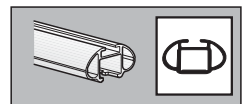
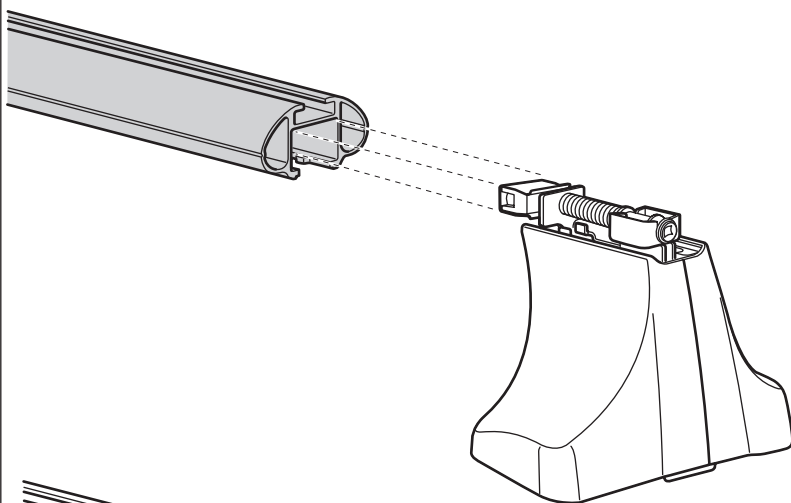
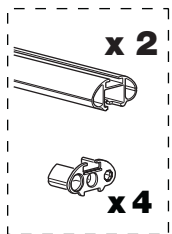
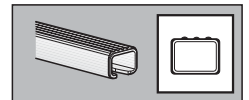
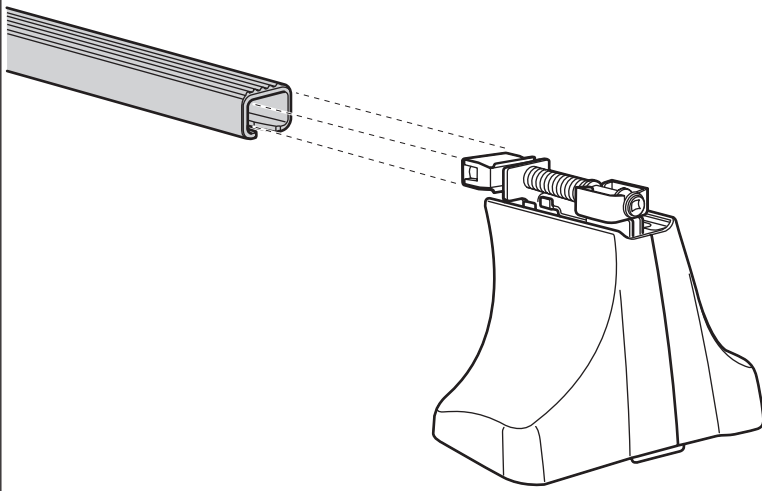
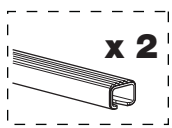
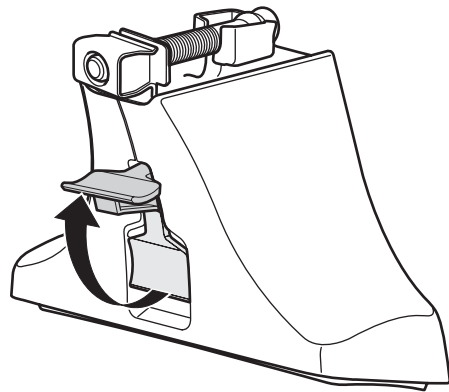
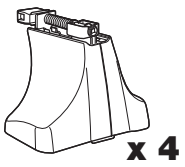

3

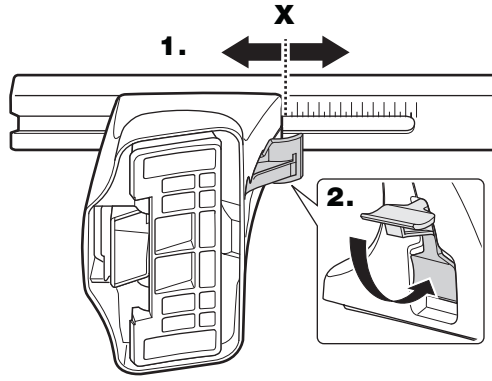

VOLKSWAGEN Golf Plus, 5-dr Hatchback, 05

X

37

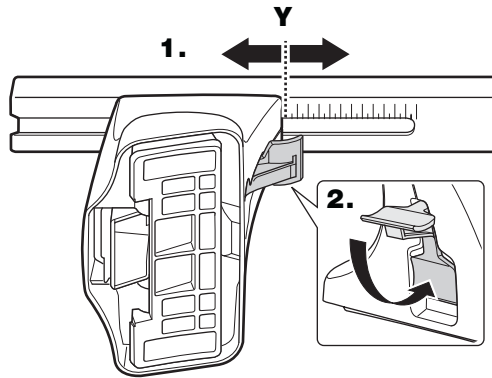
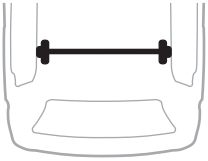

VOLKSWAGEN Golf Plus, 5-dr Hatchback, 05

Y

30

4

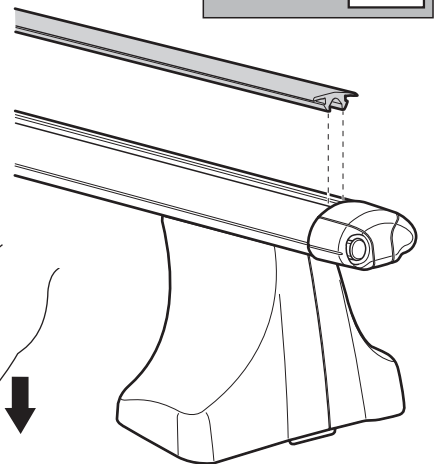
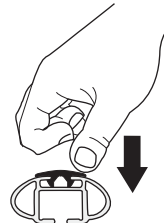
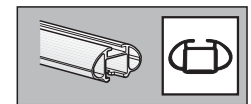
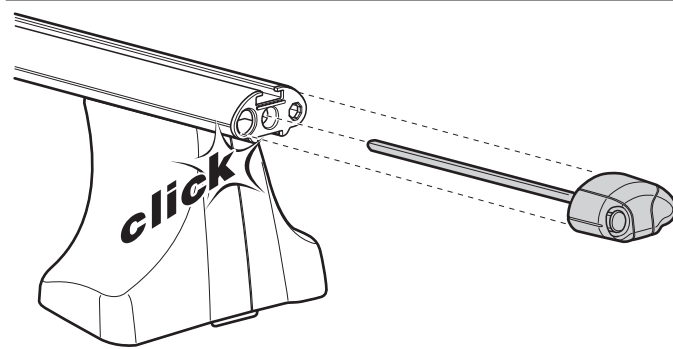
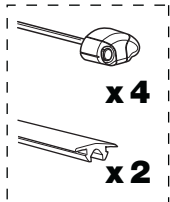
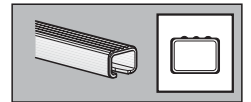
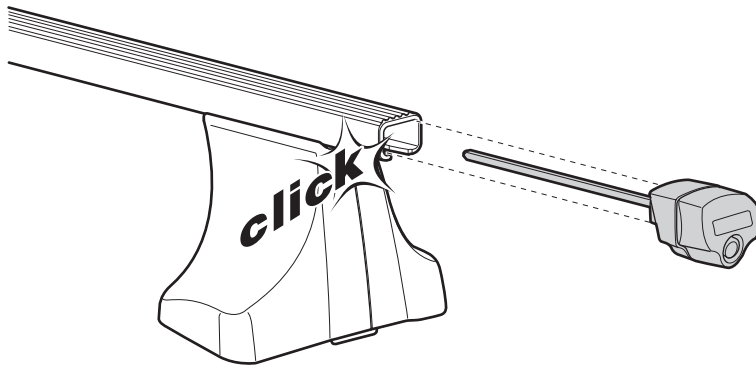
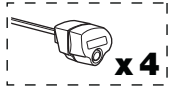

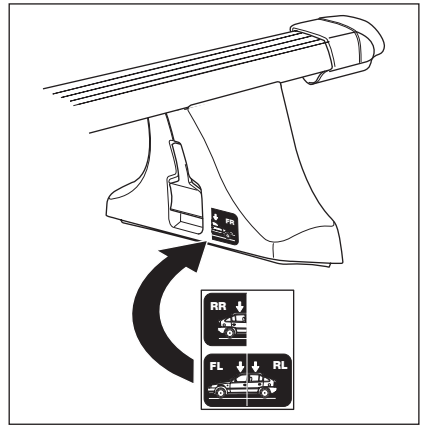
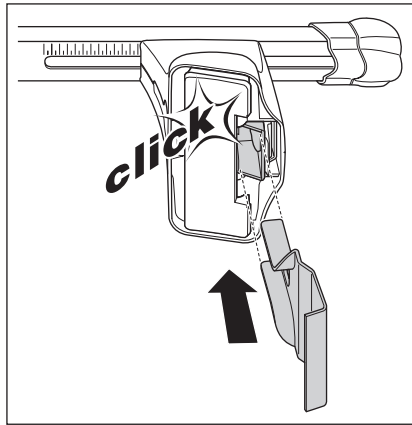
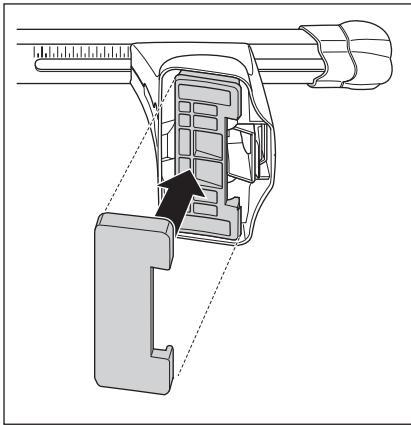

VOLKSWAGEN Golf Plus, 5-dr Hatchback, 05

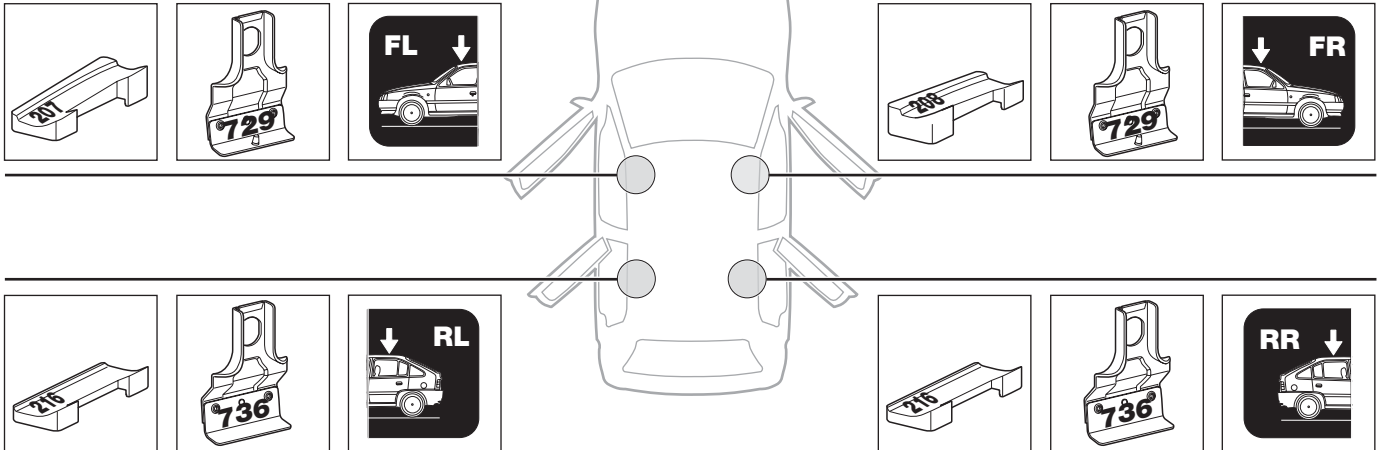

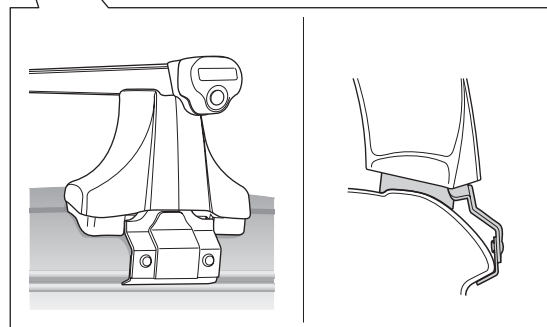
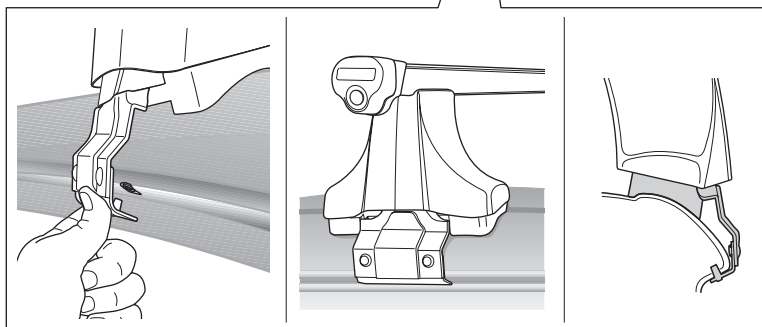
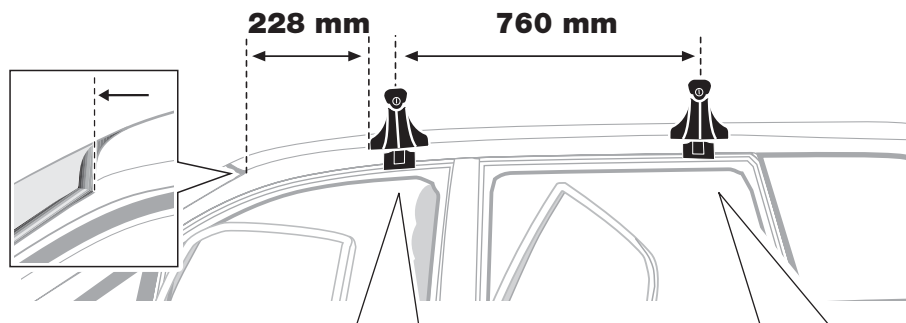
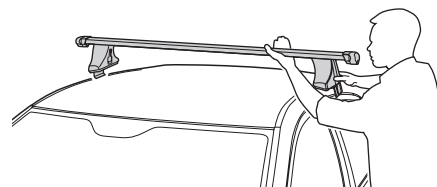
6**7**

- S** Dra åt växelvis
GB Tighten alternately
D Die Schrauben abwechselnd anziehen.
F Serrer alternativement chaque côté
NL Afwisselend aan de linker- en de rechterkant aandraaien
FIN Kierrä vuorotellen
E Alternare il serraggio delle viti
I Serrare alternativamente

- CZ** Pokrętła bagażnika dokręcaj dokręcaj naprzemiennie.
PL Śruby dokręcaj naprzemiennie
HU Egymástól függetlenül szorítandó
RU Затягивайте попеременно
EST Pinguldage vaheldumisi
SLO Privijajte izmenično.
 한국어 번갈아 가며 조이십시오.
 日本語 交互に締め付けてください。
 中文 交替拧紧

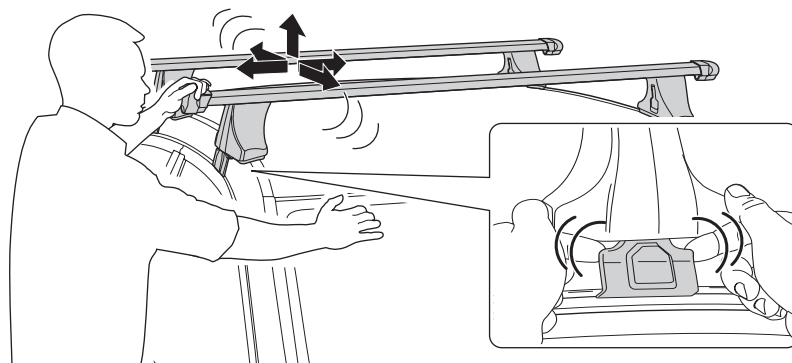
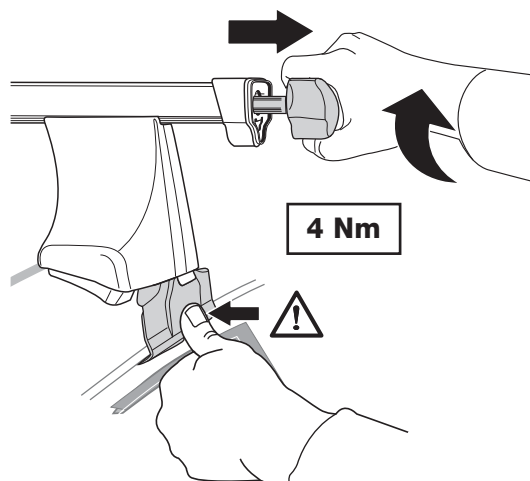
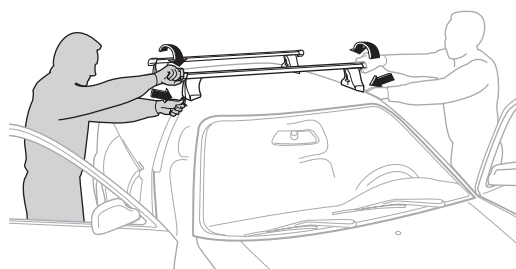

• Demontering • Removal • Demontieren • Démontage • Demontage • Irrotus • Desmontaje • Rimozione • Odmontování • Wymontowywanie
 • Leszerelés • Снятие • Eemaldamine • Odstranjevanje • 분리 • 取り外し • 拆除

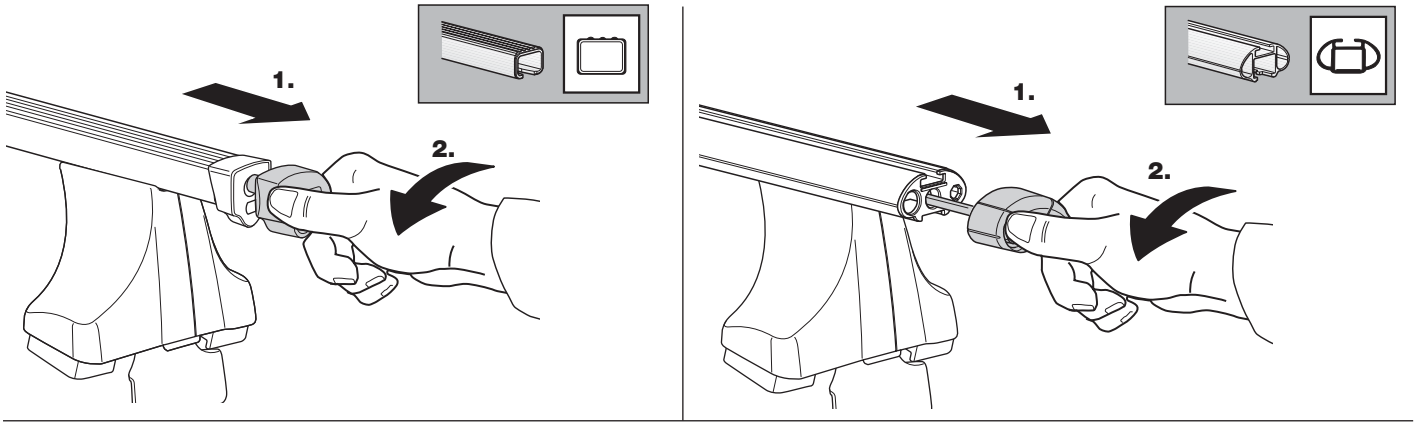

Fit Tips!

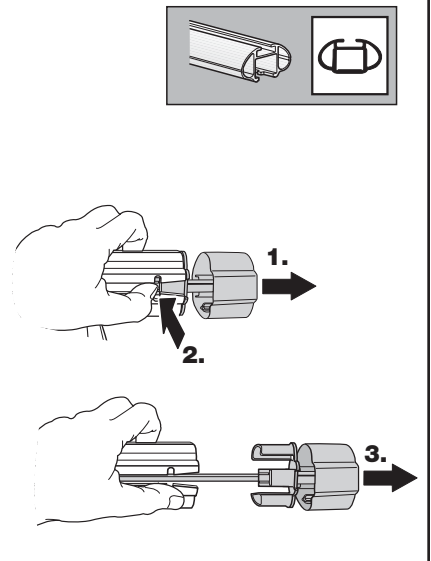
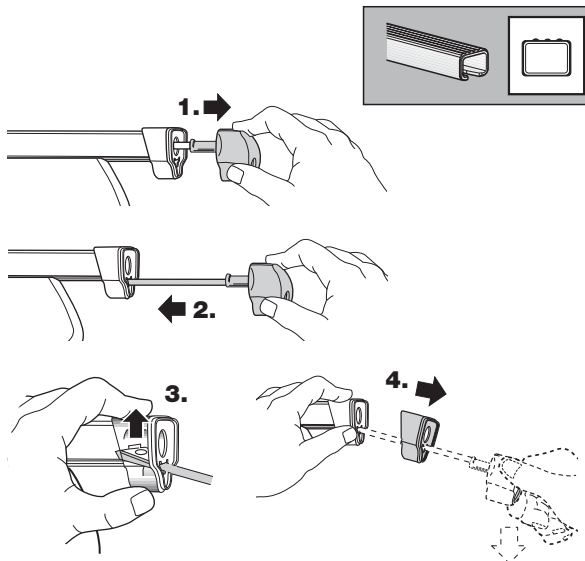
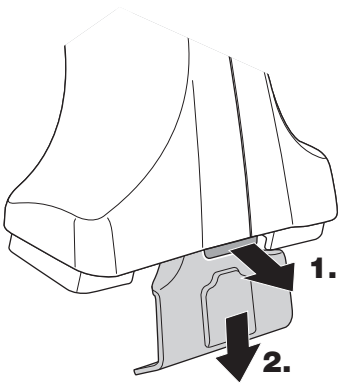

THULE
ONE
KEY
SYSTEM

